



IRCLASS
Indian Register of Shipping



CLASSIFICATION NOTES: TYPE APPROVAL OF MECHANICAL JOINTS USED IN PIPING

REVISION 6

SEPTEMBER 2024

CLASSIFICATION NOTES

Type Approval of Mechanical Joints used in Piping

Revision 6, September 2024

TABLE 1 – AMENDMENTS INCORPORATED IN THIS EDITION

These amendments will come into force on 1 January 2025

Clause	Subject/ Amendments
Section 5: Testing procedures and requirements	
Table 1, Sl. no. 6	Exemption for metal-to-metal joints (note 3) is considered applicable to fire endurance test for compression couplings and pipe unions.
Table 1, Note (1)	Note 1 amended to clarify that pressure pulsation test is mandatory for all Class I and II pipe systems and for Class III systems where pressure pulsation other than water hammer is expected.
Table 1, Note (2)	Editorial amendments are made for better clarity.

CLASSIFICATION NOTES

Type Approval of Mechanical Joints used in Piping

Revision 6, September 2024

Contents

Sections

1. General
2. Scope
3. Documentation
4. Materials
5. Testing Procedure and Requirements

Section 1

General

This Classification Note describes the type testing conditions that are required to be fulfilled for type approval of mechanical joints intended for use in marine piping systems in accordance with the IRS general “Certification Scheme for Type Approval of products”.

Alternative testing in accordance with national or international standards appropriate to the intended use and application may be considered.

The requirements of this Classification Note are applicable to any mechanical pipe joints submitted for approval from 1 January 2025 and to any renewal of type approval of existing design of mechanical pipe joint after 1 January 2025.

Section 2

Scope

- 2.1 These requirements are applicable to mechanical pipe joints including compression couplings and slip-on joints of different types for marine use.
- 2.2 The mechanical joints means devices intended for direct connection of pipe lengths other than by welding, flanges, or threaded joints. Typical examples of mechanical joints are shown in Fig.1.

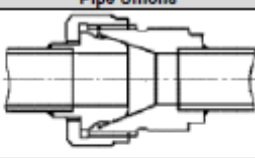
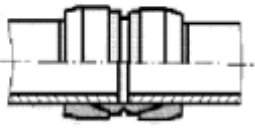
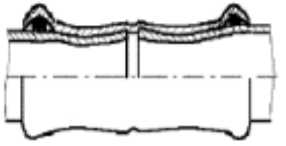
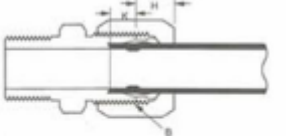
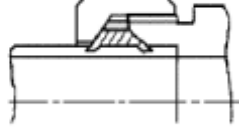
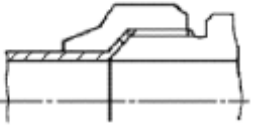
Pipe Unions	
Welded and Brazed Types	
Compression Couplings	
Swage Type	
Press Type	
Typical Compression Type	
Bite Type	
Flared Type	

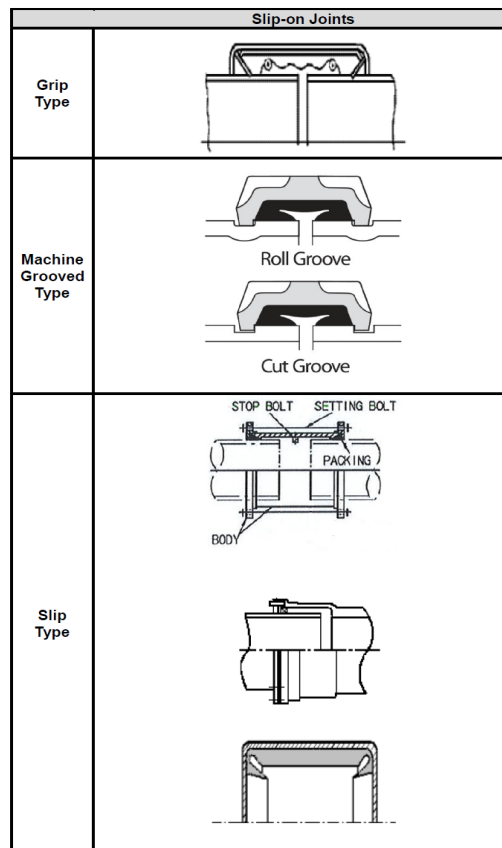

Fig 1 : Examples of Mechanical Joints

Section 3

Documentation

Following documents and information are to be submitted by Manufacturer for review and/or approval:

1. product quality assurance system implemented;
2. complete description of the product;
3. typical sectional drawings with all dimensions necessary for evaluation of joints design;
4. complete specification of materials used for all components of the assembly;
5. proposed test procedure as required in Section 5 and corresponding test reports or other previous relevant tests carried out by the manufacturer.
6. Preliminary information:
 - maximum design pressures (pressure and vacuum);
 - maximum and minimum design temperatures;
 - suitable for what medium;
 - intended services;
 - maximum axial, lateral and angular deviation, allowed by manufacturer;
 - installation details giving fitting instructions and necessary precautions to be taken while installing for the first time and while replacement.

Section 4

Materials

- 4.1 The materials used for mechanical joints are to comply with the requirements of National or International Standard, compatible with the piping material, and are to be suitable for the service intended.
- 4.2 The manufacturer has to submit evidence to substantiate that all components are adequately resistant to the working media at design pressure and temperature specified.

Section 5

Testing procedures and requirements

5.1 The purpose of tests is to demonstrate ability of the pipe joints to operate satisfactory under intended service conditions. The scope and type of tests to be conducted e.g. applicable tests, sequence of testing, and the number of specimen, etc. are subject to approval and will depend on joint design and its intended service in accordance with the requirements detailed herein. Unless otherwise specified, water or oil as test fluid is to be used.

5.2 Test Program

Testing requirements for mechanical joints are given in Table 1.

Table 1					
Tests		Types of mechanical joints			Reference Clause no.
		Compression couplings and pipes unions	Slip-on Joints		
			Grip type & machine grooved type	Slip type	
1	Tightness test	Required	Required	Required	5.6.1
2	Vibration (fatigue) test	Required	Required	Not Required	5.6.2
3	Pressure pulsation test, 1)	Required	Required	Not required	5.6.3
4	Burst pressure test	Required	Required	Required	5.6.4
5	Pull-out test	Required	Required	Not required	5.6.5
6	Fire endurance test	Required ³	Required	Required	See Note 4
7	Vacuum test	Required ³⁾	Required	Required	5.6.7 for suction lines only
8	Repeated assembly test	Required ²⁾	Required	Not required	5.6.8

Note: 1) mandatory for all Class I and II systems and for Class III systems where pressure pulsation other than water hammer is expected.

2) except permanent joint type (e.g., press type and swage type).

3) except joints with metal-to-metal tightening surfaces.

4) Fire endurance test is to be carried out if required by Pt. 4, Ch. 2, Table 2.7.1 of the *Rules and Regulations for the Construction and Classification of Steel Ships*.

5.3 Selection of Test Specimen

Test specimens are to be selected from production line or at random from the stock in accordance with the sampling plan detailed below:

Table 2		
Lot Size	No. of specimens to be selected	Acceptance criteria
0 – 10	2	All the specimens should pass the tests
10 – 30	3	
30 – 50	4	
50 – 100	5	
Where there is a variety of size of joints requiring approval, a minimum of three separate sizes, representative of the range, from each type of joint to be tested in accordance with Table 1 are to be selected.		

5.4 Mechanical Joint Assembly

Assembly of mechanical joints should consist of components selected in accordance with 5.3 and the pipe sizes appropriate to the design of the joints.

Where not specified, the length, of pipes to be connected by means of the joint to be tested is to be at least five times the pipe diameter. Before assembling the joint, conformity of components to the design requirements, is to be verified. In all cases the assembly of the joint shall be carried out only according to the manufacturer's instructions. No adjustment operations on the joint assembly, other than that specified by the manufacturer, are permitted during the test.

5.5 Test Results Acceptance Criteria

Where a mechanical joint assembly does not pass all or any part of the tests listed in Table 1, two assemblies of the same size and type that failed are to be tested and only those tests which the mechanical joint assembly failed in the first instance, are to be repeated. In the event even if one of the assemblies fails the second test, that size and type of assembly is to be considered unacceptable.

The methods and results of each test are to be recorded and reproduced as and when required.

5.6 Methods of tests

5.6.1 Tightness test

In order to ensure correct assembly and tightness of the joints, all mechanical joints are to be subjected to a tightness test, as follows.

-
- a) The mechanical joint assembly test specimen is to be connected to the pipe or tubing in accordance with the requirements of 5.4 and the manufacturers instructions, filled with test fluid and de-aerated.

Mechanical joint assemblies intended for use in rigid connections of pipe lengths, are not to be longitudinally restrained.

The pressure inside the joint assembly is to be slowly increased to 1.5 times the design pressure. This test pressure is to be retained for a minimum period of 5 minutes.

In the event of a drop in pressure or visible leakage, the test (including fire test) is to be repeated for two further specimens. If during the repeat test one test piece fails, the coupling is regarded as having failed.

An alternative tightness test procedure, such as a pneumatic test, may be accepted.

- b) For compression couplings a static gas pressure test is to be carried out to demonstrate the integrity of the mechanical joints assembly for tightness under the influence of gaseous media. The pressure is to be raised to maximum design pressure or 70 bar which ever is less.
- c) Where the tightness test is carried out using gaseous media as permitted in (a) above, then the static pressure test mentioned in (b) above need not be carried out.

5.6.2 Vibration (fatigue) test

In order to establish the capability of the mechanical joint assembly to withstand fatigue, which is likely to occur due to vibrations under service conditions, mechanical joint assemblies are to be subject to the following vibration tests.

Conclusions of the vibration tests should show no leakage or damage.

- a) Testing of compression couplings and pipe unions

Compression couplings and pipe unions intended for use in rigid pipe connections are to be tested as follows. Rigid connections are joints, connecting pipe length without free angular or axial movement.

Two lengths of pipe are to be connected by means of the joint to be tested. One end of the pipe is to be rigidly fixed while the other end is to be fitted to the vibration rig. The test rig and the joint assembly specimen being tested are to be arranged as shown in Fig. 2.

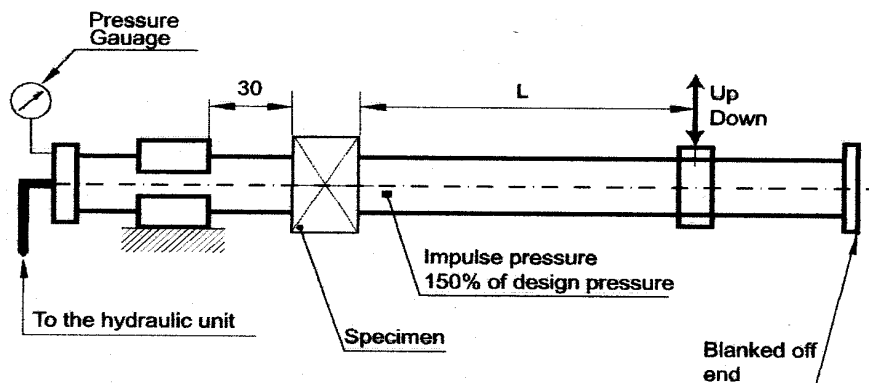

Fig. 2

The joint assembly is to be filled with test fluid, de-aerated and pressurised to the design pressure of the joint.

Pressure during the test is to be monitored. In the event of a drop in the pressure and visible leakage, the test is to be repeated as described in 5.5.

Visual examination of the joint assembly is to be carried out.

Re-tightening may be accepted once during the first 1000 cycles.

Vibration amplitude is to be within 5% of the value calculated from the following formula:

$$A = \frac{2 \times S \times L^2}{3 \times E \times D}$$

Where:

A - single amplitude, mm

L - length of the pipe, mm

S - allowable bending stress in N/mm² to be taken as 0.25 of the yield stress of the pipe material

E - modulus of elasticity of pipe material (for mild steel, E = 210 kN/mm²)

D – Outside diameter of the tube, mm

Test specimen is to withstand not less than 10⁷ cycles within the frequency range of 20 –50 Hz without leakage or damage, keeping the frequency constant during testing.

b) Grip type and machine groove type joints

Grip type joints and other similar joints containing elastic elements are to be tested in accordance with the following method.

A test rig of cantilever type used for testing fatigue strength of components may be used. The test specimen being tested is to be arranged in the rig as shown in Fig. 3.

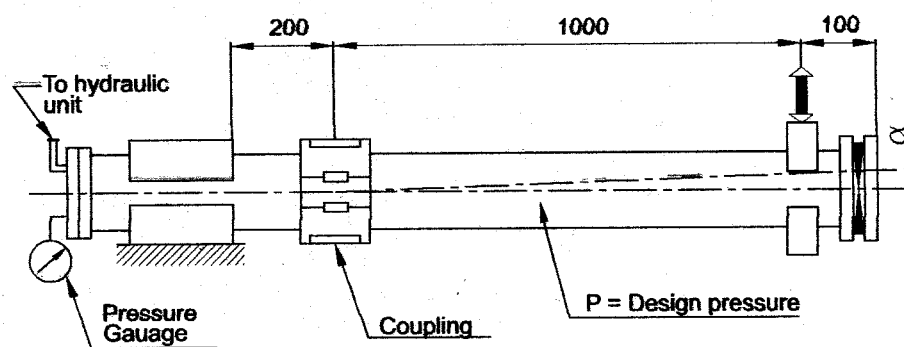

Fig. 3

Two lengths of pipes are to be connected by means of joint assembly specimen to be tested. One end of the pipe is to be rigidly fixed while the other end is to be fitted to the vibration element on the rig. The length of pipe connected to the fixed end should be kept as short as possible and in no case exceed 200 mm.

Mechanical joint assemblies are not to be longitudinally restrained.

The assembly is to be filled with test fluid, de-aerated and pressurised to the design pressure of the joint. Preliminary angle of deflection of pipe axis is to be equal to the maximum angle of deflection, recommended by the manufacturer. The amplitude is to be measured at 1m distance from the center line of the joint assembly at free pipe end connected to the rotation element of the rig. (See Fig.3)

Parameters of testing are to be as indicated below and to be carried out on the same assembly:

Number of cycles	Amplitude, mm	Frequency, Hz
$3 \cdot 10^6$	± 0.06	100
$3 \cdot 10^6$	± 0.5	45
$3 \cdot 10^6$	± 1.5	10

Pressure during the test is to be monitored. In the event of a drop in the pressure and visual signs of leakage the test is to be repeated as described in 5.5. Visual examination of the joint assembly is to be carried out for signs of damage which may eventually cause leakage.

5.6.3 Pressure pulsation test

In order to determine capability of mechanical joint assembly to withstand pressure pulsation likely to occur during working conditions, joint assemblies intended for use in rigid connections of pipe lengths, are to be tested in accordance with the following method.

The mechanical joint test specimen for carrying out this test may be the same as that used in the test in 5.6.1(a) provided it passed that test.

The vibration test in 5.6.2 and the pressure pulsation test are to be carried out simultaneously for compression couplings and pipe unions.

The mechanical joint test specimen is to be connected to a pressure source capable of generating pressure pulses of magnitude as shown in Fig 4.

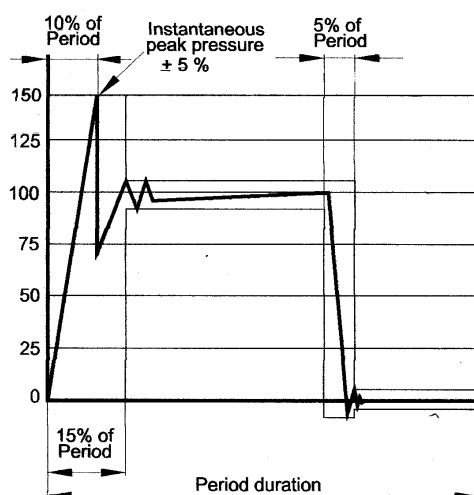

Fig.4 : Impulse pressure diagram

Impulse pressure is to be raised from 0 to 1.5 times the design pressure of the joint with a frequency equal to 30-100 cycles per minutes. The number of cycles is not be less than 5×10^5 .

The mechanical joint is to be examined visually for sign of leakage or damage during the test.

5.6.4 Burst pressure test

The mechanical joint assembly is to be subjected to a pressure equal to 4 times the design pressure as described below, in order to determine its capability to withstand the burst test.

Mechanical joint test specimen is to be connected to the pipe or tubing in accordance with the requirements of 5.4, filled with test fluid, de-aerated and pressurized to test pressure with an increasing rate of 10% of test pressure per minute. The mechanical joint assembly intended for use in rigid connections of pipe lengths is not to be longitudinally restrained.

Duration of this test is not to be less than 5 minutes at the maximum pressure. The mechanical joint test specimens used in tightness test in 5.6.1, may be used for the burst test provided they have passed the tightness test.

The specimen may exhibit a small deformation whilst under test pressure, but no leakage or visible cracks are permitted.

5.6.5 Pull-out test

In order to determine the ability of a mechanical joint assembly to withstand the axial loading likely to be encountered in service without the connecting pipe becoming detached, following pull-out test is to be carried out.

Pipes of suitable length are to be fitted to each end of the mechanical joint assembly test specimen. The test specimen is to be pressurized to design pressure. When pressure is attained, an external axial load is to be imposed with value calculated using the following formula :

$$L = \frac{\pi}{4} \cdot D^2 \cdot p$$

where: D = pipe outside diameter, mm

p = design pressure, N/mm²

L = applied axial load, N

The pressure and axial load to be maintained for a period of 5 minutes.

During the test, pressure is to be monitored and relative movement between the joint assembly and the pipe measured.

The mechanical joint assembly is to be visually examined for drop in pressure and signs of leakage or damage.

There is to be no movement between the mechanical joint assembly and the connecting pipes.

5.6.6 Fire endurance test

In order to establish capability of the mechanical joints to withstand effects of fire which may be encountered in service, mechanical joints are to be subjected to a fire endurance test. The fire endurance test is to be conducted on the selected test specimens as per the following standards.

- a) ISO 19921:2005: Ships and marine technology – Fire resistance of metallic pipe components with resilient and elastomeric seals – Test methods.
- b) ISO 19922:2005: Ships and marine technology – Fire resistance of metallic pipe components with resilient and elastomeric seals – Requirements imposed on the test bench.

Clarification to the standard requirements in ISO 19921:2005, Paragraphs 7.2, 7.4, 7.6 and 7.7:

a) If the fire test is conducted with circulating water at a pressure different from the design pressure of the joint (however of at least 5 bar) the subsequent pressure test is to be carried out to 1.5 times the design pressure.

b) If the fire test is required to be “**8 min dry + 22 min wet**” or “**30 min dry**”, (Refer Table 2.7.1 of Part 4, Chapter 2 of the *Rules and Regulations for the Construction and Classification of Steel Ships*) i.e. conducted for a period of time without circulating of water, the following test conditions apply:

Test condition “8 min dry + 22 min wet”

The test piece is not required to be rinsed with the test medium (water) in preparation for the test as required in Paragraph 7.2 of ISO 19921:2005. The exposure to fire is to be started and continued for 8 minutes with the sample dry; after 8 minutes of dry test condition the piping system is to be filled with water and test pressure is to be increased up to at least 5 bar within 2 minutes, then maintained to at least 5 bar. After further 22 minutes (i.e. 30 minutes from initial exposure to fire) the exposure to fire is to be stopped and a hydrostatic pressure test as specified in Para a) above, is to be carried out.

Test condition “30 min dry”

The exposure to fire is to be started and continued for 30 minutes with the sample dry. After 30 minutes the exposure to fire is to be stopped and a hydrostatic pressure test as specified in Para a) above, is to be carried out.

Note:

(i) For fire tests in dry condition the pressure inside the test specimen is to be monitored for a rise due to heating of the enclosed air. Means of pressure relief should be provided where deemed necessary.

(ii) High pressures created during this test can result in failure of the test specimen. Precautions are to be taken to protect personnel and facilities.

(iii) Paragraph 7.5 of ISO 19921:2005 does not apply to the dry tests and no forced air circulation is to be arranged.

(iv) For fire endurance test requiring exposure time greater than 30 minutes test conditions are adjusted to meet the extended required total exposure time. In all cases for dry-wet test, the minimum dry test exposure time is 8 minutes.

c) A selection of representative nominal bores may be tested in order to evaluate the fire resistance of a series or range of mechanical joints of the same design. When a mechanical joint of a given nominal bore (D_n) is so tested then other mechanical joints falling in the range D_n to $2xD_n$ (both inclusive) are considered accepted.

d) Alternative test methods and/or test procedures considered to be at least equivalent may be accepted at the discretion of IRS in cases where the test pieces are too large for the test bench and cannot be completely enclosed by the flames.

e) Where thermal insulation is acceptable as a means of providing fire resistance, following requirements apply:

(i) Thermal insulation materials applied on couplings are to be non-combustible according to ISO 1182:2020 as required by Fire Test Procedures Code defined in Regulation 3 of SOLAS Chapter II-2 as amended by IMO resolutions up to MSC. 421(98).

Precautions are to be taken to protect the insulation from being impregnated with flammable oils.

(ii) At least the fire endurance and the vibration testing in Table 1 are to be carried out with thermal insulation in place.

(iii) A service restriction is to be stated on the type approval certificate that the mechanical joints are to be fitted with thermal insulation during the installation in cases where the mechanical joints are used where fire resistance is required, unless mechanical joints are delivered already fitted with thermal insulation before installation.

5.6.7 Vacuum test

In order to establish the capability of the mechanical joint assembly to withstand internal pressures below atmospheric, similar to the conditions likely to be encountered under service conditions, the following vacuum test is to be carried out.

The mechanical joint assembly is to be connected to a vacuum pump and subjected to a pressure of 170 mbar absolute. Once this pressure is stabilized the specimen under test is to be isolated from the vacuum pump and the pressure is to be maintained for a period of 5 minutes.

No internal pressure rise is permitted.

5.6.8 Repeated assembly test

The mechanical joint test specimen is to be dismantled and reassembled 10 times in accordance with manufacturers instructions and then subjected to a tightness test as defined in 5.6.1

End of Classification Note