

INDIAN REGISTER OF SHIPPING

CLASSIFICATION NOTES

Type Approval of Mechanical Joints used in Piping

Revision 02

January 2014



IRCLASS
Indian Register of Shipping

CLASSIFICATION NOTES

Type Approval of Mechanical Joints used in Piping

Revision 02 : January, 2014

Contents

Sections

1. General
2. Scope
3. Documentation
4. Materials
5. Testing Procedure and Requirements

1.0 General

This Classification Note describes the type testing conditions that are required to be fulfilled for type approval certificate of mechanical joints intended for use in marine piping systems in accordance with the IRS general “Certification Scheme for Type Approval of products”.

Alternative testing in accordance with national or international standards appropriate to the intended use and application may be considered.

2.0 Scope

- 2.1 These requirements are applicable to mechanical joints including compression couplings and slip-on joints of different types for marine use.
- 2.2 The mechanical joints means devices intended for direct connection of pipe lengths other than by welding, flanges, or threaded joints. Typical examples of mechanical joints are shown in Fig.1.

Fig. 1 : Examples of mechanical joints

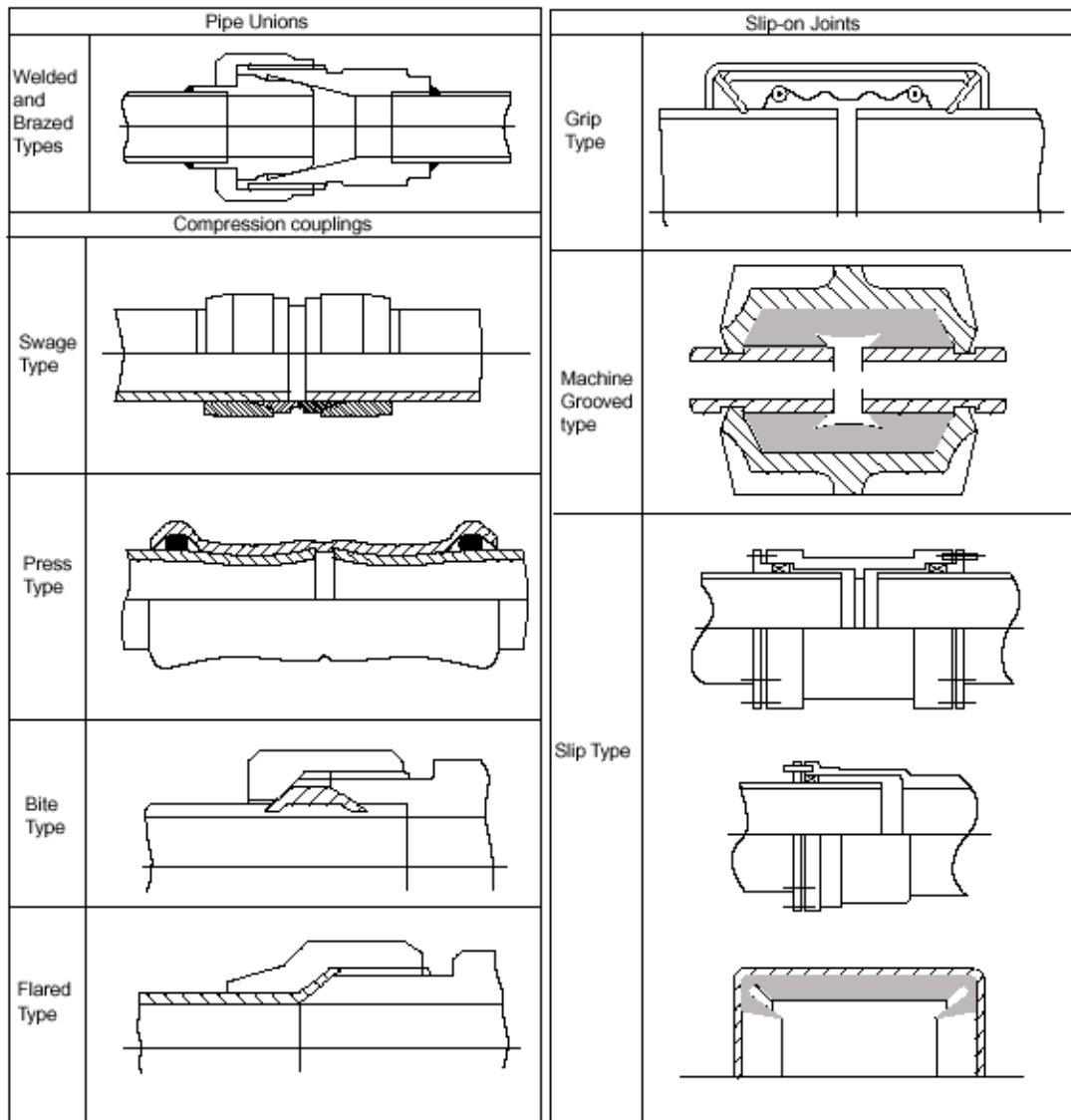

3.0 Documentation

Following documents and information are to be submitted by Manufacturer for review and/or approval:

1. product quality assurance system implemented;
2. complete description of the product;
3. typical sectional drawings with all dimensions necessary for evaluation of joints design;
4. complete specification of materials used for all components of the assembly;
5. proposed test procedure as required in Section 5 and corresponding test reports or other previous relevant tests carried out by the manufacturer.
6. Preliminary information:
 - maximum design pressures (pressure and vacuum);
 - maximum and minimum design temperatures;
 - suitable for what medium;
 - intended services;
 - maximum axial, lateral and angular deviation, allowed by manufacturer;
 - installation details giving fitting instructions and necessary precautions to be taken while installing for the first time and while replacement.

4.0 Materials

- 4.1 The materials used for mechanical joints are to comply with the requirements of National or International Standard and are to be suitable for the service intended.
- 4.2 The manufacturer has to submit evidence to substantiate that all components are adequately resistant to the working media at design pressure and temperature specified.

5.0 Testing procedures and requirements

5.1 The purpose of tests is to demonstrate ability of the pipe joints to operate satisfactory under intended service conditions. The scope and type of tests to be conducted e.g. applicable tests, sequence of testing, and the number of specimen, etc. are subject to approval and will depend on joint design and its intended service in accordance with the requirements detailed herein.

5.2 Test Program

Testing requirements for mechanical joints are given in Table 1.

Table 1					
Tests		Types of mechanical joints			Reference Clause no.
		Compression couplings and pipes unions	Slip-on Joints		
			Grip type & machine grooved type	Slip type	
1	Tightness test	Required	Required	Required	5.6.1
2	Vibration (fatigue) test	Required	Required	Not Required	5.6.2
3	Pressure pulsation test, 1)	Required	Required	Not required	5.6.3
4	Burst pressure test	Required	Required	Required	5.6.4
5	Pull-out test	Required	Required	Not required	5.6.5
6	Fire endurance test	Required	Required	Required	4)
7	Vacuum test	Required 3)	Required	Required	5.6.7 for suction lines only
8	Repeated assembly test	Required 2)	Required	Not required	5.6.8

Note:

- 1) for use in those systems where pressure pulsation other than water hammer is expected
- 2) except press type.
- 3) except joints with metal-to-metal tightening surfaces.
- 4) Fire endurance test is to be carried out if required by Pt. 4, Ch. 2, Table 2.7.1 of Main Rules.

5.3 Selection of Test Specimen

Test specimens are to be selected from production line or at random from the stock in accordance with the sampling plan detailed below:

Lot Size	No. of specimens to be selected	Acceptance criteria
0 – 10	2	All the specimens should pass the tests
10 – 30	3	
30 – 50	4	
50 – 100	5	

When Type Approval for various sizes of a type of joints is sought, minimum of three separate sizes representative of the range, from each type of joints are to be subjected to the tests listed in Table 1.

5.4 Mechanical Joint Assembly

Assembly of mechanical joints should consist of components selected in accordance with 5.3 and the pipe sizes appropriate to the design of the joints.

Where not specified, the length, of pipes to be connected by means of the joint to be tested is to be at least five times the pipe diameter. Before assembling the joint, conformity of components to the design requirements, is to be verified. In all cases the assembly of the joint shall be carried out only according to the manufacturer's instructions. No adjustment operations on the joint assembly, other than that specified by the manufacturer, are permitted during the test.

5.5 Test Results Acceptance Criteria

Where a mechanical joint assembly does not pass all or any part of the tests listed in Table 1, two assemblies of the same size and type that failed in the first instance, are to be repeated. In the event even if one of the assemblies fails the second test, that size and type of assembly is to be considered unacceptable.

5.6 Methods of tests

5.6.1 Tightness test

In order to ensure correct assembly and tightness of the joints, all mechanical joints are to be subjected to a tightness test, as follows.

- a) Mechanical joint assembly test specimen is to be connected to the pipe or tubing in accordance with the requirements of 5.4 and the manufacturers instructions, filled with test fluid and de-aerated.

Mechanical joint assemblies intended for use in rigid connections of pipe lengths, are not to be longitudinally restrained.

Pressure inside the joint assembly is to be slowly increased to 1.5 times of design pressure. This test pressure is to be retained for a minimum period of 5 minutes.

In the event where there is a drop in pressure or there is visual indication of leakage, the test (including fire test) shall be repeated for two test pieces. If during the repeat test one test piece fails, the testing is regarded as having failed.

Other alternative tightness test procedure, such as pneumatic test, may be accepted.

- b) For compression couplings a static gas pressure test is to be carried out to demonstrate the integrity of the mechanical joints assembly for tightness under the influence of gaseous media. The pressure is to be raised to maximum design pressure or 70 bar which ever is less.
- c) Where the tightness test is carried out using gaseous media as permitted in (a) above, then the static pressure test mentioned in (b) above need not be carried out.

5.6.2 Vibration (fatigue) test

In order to establish the capacity of the mechanical joint assembly to withstand fatigue, which is likely to occur due to vibrations under service conditions, mechanical joints assembly is to be subject to the following vibration test.

Conclusions of the vibration tests should show no leakage or damage, which could subsequently lead to a failure.

- a) Testing of compression couplings and pipe unions

Compression couplings, pipe unions or other similar joints intended for use in rigid connections of pipe are to be tested in accordance with this methods described as follows. Rigid connections are joints, connecting pipe length without free angular or axial movement.

Two lengths of pipe are to be connected by means of the joint to be tested. One end of the pipe is to be rigidly fixed while the other end is to be fitted to the vibration rig. The test rig and the joint assembly specimen being tested is to be arranged as shown in Fig. 2.

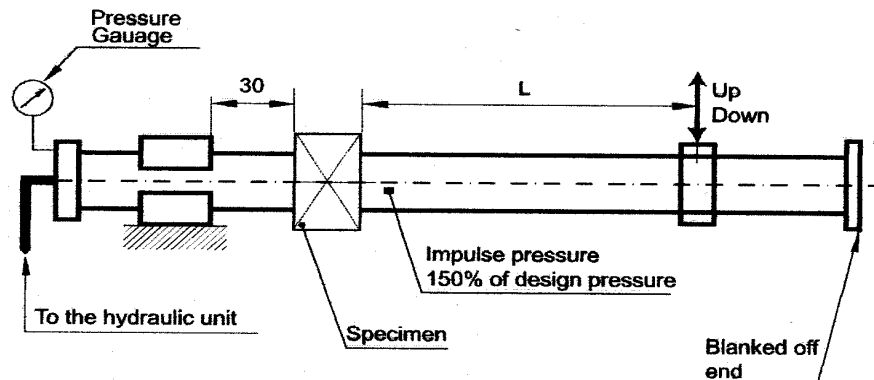

Fig.2

The joint assembly is to be filled with test fluid, de-aerated and pressurised to the design pressure of the joint.

Visual examination of the joint assembly is to be carried out for signs of damage which may eventually lead to joint leakage.

Re-tightening may be accepted once during the first 1000 cycles.

Vibration amplitude is to be within 5% of the value calculated from the following formula:

$$A = \frac{2 \times S \times L^2}{3 \times E \times D}$$

Where:

A - single amplitude, mm

L - length of the pipe, mm

S - allowable bending stress in N/mm² to be taken as 0.25 of the yield stress of the pipe material

E - modulus of elasticity of pipe material (for mild steel, E = 210 kN/mm²)

Test specimen is to withstand not less than 10⁷ cycles within the frequency range of 20 –50 Hz without leakage or damage, keeping the frequency constant during testing.

b) Grip type and machine groove type joints

Grip type joints and other similar joints containing elastic elements are to be tested in accordance with the following method.

A test rig of cantilever type used for testing fatigue strength of components may be used. The test specimen being tested is to be arranged in the rig as shown in Fig. 3.

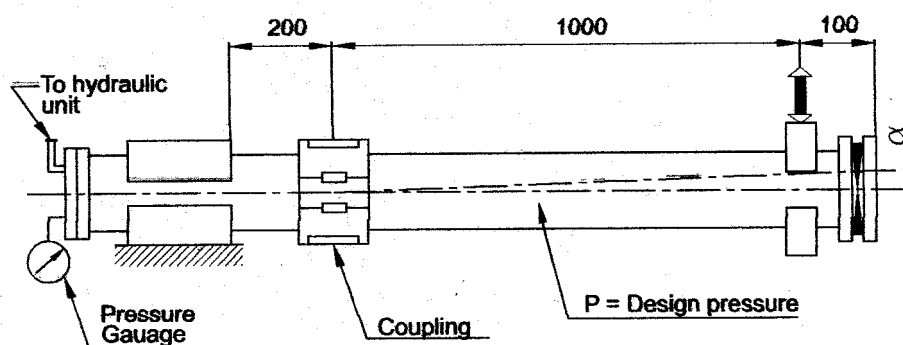

Fig. 3

Two lengths of pipes are to be connected by means of joint assembly specimen to be tested. One end of the pipe is to be rigidly fixed while the other end is to be fitted to the vibration element on the rig. The length of pipe connected to the fixed end should be kept as short as possible and in no case exceeds 200 mm.

Mechanical joint assemblies are not to be longitudinally restrained.

The assembly is to be filled with test fluid, de-aerated and pressurised to the design pressure of the joint. Preliminary angle of deflection of pipe axis is to be equal to the maximum angle of deflection, recommended by the manufacturer. The amplitude is to be measured at 1m distance from the center line of the joint assembly at free pipe end connected to the rotation element of the rig. (See fig.2)

Parameters of testing are to be as indicated below and to be carried out on the same assembly:

Number of cycles	Amplitude, mm	Frequency, Hz
3 10 ⁶	± 0.06	100
3 10 ⁶	± 0.5	45
3 10 ⁶	± 1.5	10

5.6.3 Pressure pulsation test

In order to determine capability of mechanical joint assembly to withstand pressure pulsation likely to occur during working conditions, joint assemblies intended for use in rigid connections of pipe lengths, are to be tested in accordance with the following method.

The mechanical joint test specimen for carrying out this test may be the same as that used in the test in 5.6.1(a) provided it passed that test.

The vibration test in 5.6.2 and the pressure pulsation test are to be carried out simultaneously for compression couplings and pipe unions.

The mechanical joint test specimen is to be connected to a pressure source capable of generating pressure pulses of magnitude as shown in Fig 4.

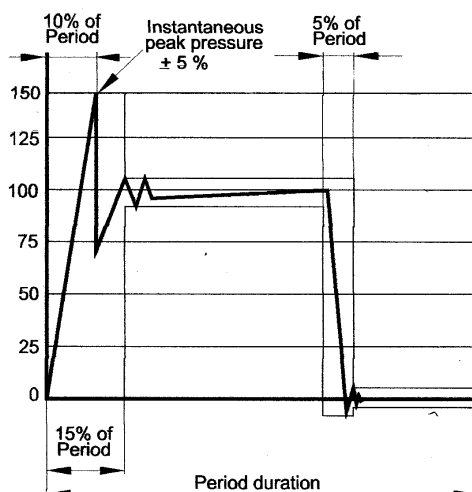

Fig.4 : Impulse pressure diagram

Impulse pressure is to be raised from 0 to 1.5 times the design pressure of the joint with a frequency equal to 30-100 cycles per minutes. The number of cycles is not be less than 5×10^5 .

The mechanical joint is to be examined visually for sign of leakage or damage during the test.

5.6.4 Burst pressure test

The mechanical joint assembly is to be subjected to a pressure equal to 4 times the design pressure as described below, in order to determine its capability to withstand the burst test.

Mechanical joint test specimen is to be connected to the pipe or tubing in accordance with the requirements of 5.4, filled with test fluid, de-aerated and pressurized to test pressure with an increasing rate of 10% of test pressure

per minute. The mechanical joint assembly intended for use in rigid connections of pipe lengths is not to be longitudinally restrained.

Duration of this test is not to be less than 5 minutes at the maximum pressure. This pressure value will be annotated.

The mechanical joint test specimens used in tightness test in 5.6.1, may be used for the burst test provided they have passed the tightness test.

The specimen may have small deformation whilst under test pressure, but no leakage or visible cracks are permitted.

5.6.5 Pull-out test

In order to determine ability of a mechanical joint assembly to withstand axial load likely to be encountered in service without the connecting pipe from becoming detached, following pull-out test is to be carried out.

Pipe length of suitable size is to be fitted to each end of the mechanical joints assembly test specimen. The test specimen is to be pressurized to design pressure. When pressure is attained, an external axial load is to be imposed with value calculated by the following formula :

$$L = \frac{\pi}{4} \cdot D^2 \cdot p$$

where: D = pipe outside diameter, mm

p = design pressure, N/mm²

L = applied axial load, N

The pressure and axial load to be maintained for a period of 5 minutes.

During the test, pressure is to be monitored and relative movement between the joint assembly and the pipe measured.

The mechanical joint assembly is to be visually examined for drop in pressure and signs of leakage or damage.

There is to be no movement between mechanical joint assembly and the connecting pipes.

5.6.6 Fire endurance Test

In order to establish capability of the mechanical joints to withstand effects of fire which may be encountered in service, mechanical joints are to be subjected to a fire endurance test. The fire endurance test is to be conducted on the selected test specimens as per the following standards.

- a) ISO 19921:2005(E) : Ships and marine technology – Fire resistance of metallic pipe components with resilient and elastomeric seals – Test methods.

- b) ISO 19922:2005(E) : Ships and marine technology – Fire resistance of metallic pipe components with resilient and elastomeric seals – Requirements imposed on the test bench.

Clarification to the standard requirements:

- a) A selection of representative nominal bores may be tested in order to evaluate the fire resistance of a series or range of mechanical joints of the same design. When a mechanical joint of a given nominal bore (D_n) is so tested then other mechanical joints falling in the range D_n to $2xD_n$ (both inclusive) are considered accepted.

5.6.7 Vacuum test

In order to establish capability of mechanical joint assembly to withstand internal pressures below atmosphere, similar to the conditions likely to be encountered under service conditions, following vacuum test is to be carried out.

Mechanical joint assembly is to be connected to a vacuum pump and subjected to a pressure 170 mbar absolute. Once this pressure is stabilized the mechanical joint assembly test specimen under test are to be isolated from the vacuum pump and this pressure is to be retained for a period of 5 minutes.

Pressure is to be monitored during the test.

No internal pressure rise is permitted.

5.6.8 Repeated assembly test

Mechanical joint test specimen are to be dismantled and reassembled 10 times in accordance with manufacturers instructions and then subjected to a tightness test as defined in 5.6.1