

INDIAN REGISTER OF SHIPPING

CLASSIFICATION NOTES

Guidelines for Non-Destructive Examination of Steel Castings for Marine Application

January 2005



IRCLASS
Indian Register of Shipping

CLASSIFICATION NOTES

Guidelines for Non-Destructive Examination of Steel Castings for Marine Application

January 2005

Contents

Sections

- 1. General**
 - 1.1 Scope
- 2. Personnel Requirements**
 - 2.1 Qualifications
- 3. Casting Condition**
 - 3.1 Heat Treatment
 - 3.2 Surface Condition
- 4. Extent of Examinations**
 - 4.1 Castings to be examined
 - 4.2 Zones to be examined
- 5. Examination Procedures**
 - 5.1 Visual Inspections
 - 5.2 Surface Crack Detection
 - 5.3 Volumetric Inspections
- 6. Acceptance Criteria**
 - 6.1 Visual Testing
 - 6.2 Surface Crack Detection
 - 6.3 Volumetric Testing
- 7. Reporting**
- 8. Rectification of Defects**

1. General

1.1 Scope

- 1.1.1 These guidelines complement the requirements for hull and machinery steel castings given in IRS Rules Pt.2, Ch.4 “Steel Castings” and in Pt.4, Ch.4 “Prime Movers and Propulsion Shafting systems” and contain general guidance on the extent, methods and recommended quality levels applicable to the non-destructive examinations (NDE), of marine steel castings, except in those cases where alternative criteria have been otherwise approved or specified.
- 1.1.2 The requirements in these guidelines may also be applied for other machinery components, giving due consideration to their materials, types, shapes and stress conditions etc.

2. Personnel Requirements

2.1 Qualifications

- 2.1.1 Personnel carrying out NDE are to be qualified and certified to at least Level II of a recognised certification scheme such as EN 473, ISO 9712 or ASNT-TC-1A/ ISNT.
- 2.1.2 Personnel responsible for the NDE activity including approval of procedures are to be qualified and certified to Level III of ISNT/ASNT.

3. Casting Condition

3.1 Heat Treatment

- 3.1.1 Non-destructive examinations applied for acceptance purposes are to be made after the final heat treatment of the casting. Where intermediate inspections have been performed, the manufacturer is to furnish the documentation of the results upon request to the Surveyor.

3.2 Surface Condition

- 3.2.1 Castings are to be examined in the final delivery condition free from any extraneous materials such as scale, dirt, grease or paint that may affect the efficacy of the testing being performed. A thin coating of contrast paint is permissible when using magnetic particle techniques.
- 3.2.2 Unless otherwise specified in the order, magnetic particle test is to be carried out within 0.3 [mm] of the final machined surface condition for AC techniques or within 0.8 [mm] for DC techniques.

3.2.3 Ultrasonic testing is to be carried out after the castings have been ground, machined or shot blasted to a suitable condition. The surfaces of castings to be examined is to be such that adequate coupling can be established between the probe and the casting and that excessive wear of the probe is avoided.

4. Extent of Examination

4.1 Castings to be examined

4.1.1 Castings to be examined by NDE methods are identified in Figures 1 to 6. The list of castings is not definitive. Criteria for the examination of other castings not indicated in these guidelines will be subject to prior agreement.

4.2 Zones to be examined

4.2.1 Zones to be examined in nominated castings are identified in Figures 1 to 6. Examinations are to be made in accordance with an approved inspection plan. The plan is to specify the extent of the examination, the examination procedure, the quality level or, where necessary, quality level for different locations of the castings.

4.2.2 In addition to the areas identified in Figures 1 to 6, surface inspections are to be carried out in the following locations:

- at all accessible fillets and changes of section,
- in way of fabrication weld preparation, for a band width of 30 [mm],
- in way of chaplets,
- in way of weld repairs,
- at positions where surplus metal has been removed by flame cutting, scarifying or arc-air-gouging.

4.2.3 Ultrasonic testing is to be carried out in the zones indicated in Figures 1 to 6 and also at the following locations:

- in way of all accessible fillets and at pronounced changes of section,
- in way of fabrication weld preparations for a distance of 50 [mm] from the edge,
- in way of weld repairs where the original defect was detected by ultrasonic testing,
- in way of riser positions,
- in way of machined areas particularly those subject to further machining such as bolt hole positions.

In the case of castings such as rudder horns, which may have a large surface area still untested after the above inspections have been applied, an additional ultrasonic inspection of the untested areas are to be made along continuous perpendicular grid lines on nominal 225 [mm] centres, scanning from one surface only.

5. Examination Procedures

5.1 Visual Inspection

5.1.1 Steel castings which are required to undergo NDE are to be subjected to 100% visual examination of all surfaces to ensure that the surface is suitable for the proposed NDT. Unless otherwise agreed, the visual and surface crack detection inspections are to be carried out in the presence of the Surveyor.

5.2 Surface Crack Detection

5.2.1 The testing procedures, apparatus and conditions of magnetic particle testing and liquid penetrant testing are to comply with recognized national or international standards. Magnetic particle inspection will be carried out in preference to liquid penetrant testing except in the following cases:

- austenitic stainless steels,
- interpretation of open visual or magnetic particle indications,
- at the instruction of the Surveyor.

5.2.2 For magnetic particle testing attention is to be paid to the contact between the casting and the clamping devices or stationary magnetization benches in order to avoid local overheating or burning damage in its surface. Prods are not to be permitted on finished machined items. Note that the use of solid copper at the prod tips must be avoided due to the risk of copper penetration.

5.2.3 When indications have been detected as a result of the surface inspection, acceptance or rejection is to be decided in accordance with Section 6.

5.3 Volumetric Inspection

5.3.1 Volumetric inspection in accordance with these guidelines is to be carried out by ultrasonic testing using the contact method with straight beam and/or angle beam technique. The testing procedures, apparatus and conditions of ultrasonic testing are to comply with the recognized national or international standards. Radiographic testing may be carried out on the basis of prior agreement with IRS.

- 5.3.2 Unless otherwise considered necessary, only those areas shown in the agreed inspection plan need to be tested.
- 5.3.3 Ultrasonic scans are to be made using a 0° probe of 1 – 4 MHz (usually 2MHz) frequency. Whenever possible scanning is to be performed from both surfaces of the casting and from surfaces perpendicular to each other. Lower frequency probes are recommended in order to increase signal to noise ratio.
- 5.3.4 The back wall echo obtained on parallel sections to be used to monitor variations in probe coupling and material attenuation. Any reduction in the amplitude of the back wall echo without evidence of intervening defects is to be corrected. Attenuation in excess of 30 dB/m could be indicative of an unsatisfactory annealing heat treatment.
- 5.3.5 Machined surfaces, especially those in the vicinity of riser locations and in the bores of stern boss castings, is also to be subject to a near surface (25 mm) scan using a twin crystal 0° probe. Additional scans on machined surfaces are of particular importance in cases where boltholes are to be drilled or where surplus material such as 'padding' has been removed by machining thus moving the scanning surface closer to possible areas of shrinkage. Also, it is advisable to examine the machined bores of castings using circumferential scans with 70° probes in order that axial radial planar flaws such as hot tears can be detected. Fillet radii should be examined using 45°, 60° or 70° probes scanning from the surfaces / direction likely to give the best reflection.
- 5.3.6 In the examinations of those zones nominated for ultrasonic examination the reference sensitivity is to be established against a 6 [mm] diameter disk reflector. Sensitivity can be calibrated either against 6 [mm] diameter flat bottomed hole(s) in a reference block (or series of blocks) corresponding to the thickness of the casting provided that a transfer correction is made, or, as a preferred alternative, by using the DGS (distance-gain-size) method. The DGS diagrams issued by a probe manufacturer identify the difference in dB between the amplitude of a back wall echo and that expected from a 6 [mm] diameter disk reflector. By adding this difference to the sensitivity level initially set by adjusting a back wall echo to a reference height e.g. 80%, the amended reference level will be representative of a 6 [mm] diameter disk reflector. Similar calculations can be used for evaluation purposes to establish the difference in dB between a back wall reflector and disk reflectors of other diameters such as 12 or 15 [mm].
- 5.3.7 Having made any necessary corrections for differences in attenuation or surface condition between the reference block and the casting any indications received from the nominated zones in the casting that exceed the 6 [mm] reference level is to be marked for evaluation against the criteria given in 6.3 below. Evaluation is to include

additional scans with angle probes in order that the full extent of the discontinuity can be plotted.

6. Acceptance Criteria

6.1 Visual Testing

6.1.1 All castings are to be free of cracks, crack-like indications, hot tears, cold shuts or other injurious indications. Thickness of the remains of sprues or risers is to be within the casting dimensional tolerance.

6.1.2 Additional magnetic particle, dye penetrant or ultrasonic testing may be required for a more detailed evaluation of surface irregularities at the request of the Surveyor.

6.2 Surface Crack Detection

6.2.1 The following definitions relevant to indications apply:

Linear indication	=	an indication in which the length is at least three times the width
Non-linear indication	=	an indication of circular or elliptical shape with a length less than three times the width
Aligned indication	=	three or more indications in a line, separated by 2 [mm] or less edge-to-edge
Open indication	=	an indication visible after removal of the magnetic particles or that can be detected by the use of contrast dye penetrant
Non-open indication	=	an indication that is not visually detectable after removal of the magnetic particles or that cannot be detected by the use of contrast dye penetrant
Relevant indication	=	an indication that is caused by a condition or type of discontinuity that requires evaluation. Only the indications which have any dimension greater than 1.5 [mm] are to be considered relevant.

6.2.2 For the purpose of evaluating indications, the surface is to be divided into reference band length of 150 [mm] for level MT1/PT1 and into reference areas of 22500 [mm²] for level MT2/PT2. The band length and/or areas are to be taken in the most unfavourable locations relative to the indications being evaluated.

6.2.3 The following quality levels recommended for magnetic particle testing (MT) and/or liquid penetrant testing (PT) area:

Level MT1/PT1 – fabrication weld preparation and weld repairs.

Level MT2/PT2 – other locations nominated for surface crack detection in Figures 1 to 6.

The allowable numbers and sizes of indications in the reference band length and/or area are given in Table 1. The required quality level is to be shown on the manufacturer's inspection plan. Cracks and hot tears are not acceptable.

Table 1 : Allowable number and size of indications in a reference band length / area				
Quality Level	Max. number of indications	Type of indication	Max. number for each type	Max. dimension of single indication, [mm]²
MT1/PT1	4 in 150 mm length	Non-linear	4 ¹⁾	5
		Linear	4 ¹⁾	3
		Aligned	4 ¹⁾	3
MT2/PT2	20 in 22500 [mm ²] area	Non-linear	10	7
		Linear	6	5
		Aligned	6	5
Notes :				
1) 30 [mm] min. between relevant indications.				
2) In weld repairs, the maximum dimension is 2 [mm].				

6.3 Volumetric Testing

6.3.1 Acceptance criteria for ultrasonic testing are identified in Table 2 as UT1 and UT2. As stated in 4.2.1 the quality levels applicable to the zones to be examined are to be identified on an inspection plan. The following quality levels are nominated for the castings identified in Figures 1 to 6.

Level UT1 is applicable to:

- fabrication weld preparations for a distance of 50 [mm].
- 50 [mm] depth from the final machined surface including boltholes.
- Fillet radii to a depth of 50 [mm] and within distance of 50 [mm] from the radius end.
- Castings subject to cyclic bending stresses e.g. rudder horn, rudder castings and rudder stocks – the outer one third of thickness in the zones nominated for volumetric examination by Figures 1 to 6.
- discontinuities within the examined zones interpreted to be cracks or hot tears.

Level UT2 is applicable to:

- other locations nominated for ultrasonic testing in Figures 1 to 6 or on the inspection plan.
- positions outside locations nominated for level UT1 examination where feeders and gates have been removed.
- Castings subject to cyclic bending stresses – at the central one third of thickness in the zones nominated for volumetric inspection by Figures 1 to 6.

6.3.2 Ultrasonic acceptance criteria for other casting areas not nominated in Figures 1 to 6 will be subject to special consideration based on the anticipated stress levels and the type, size and position of the discontinuity.

Table 2 : Ultrasonic acceptance criteria for steel castings			
Quality Level	Allowable disc shape according to DGS ¹⁾ [mm]	Max. number of indications to be registered ²⁾	Allowable length of linear indications [mm] ³⁾
UT1	> 6	0	0
UT2	12 – 15	5	50
	> 15	0	0

Notes:

- 1) DGS : distance-gain-size
- 2) Grouped in an area measuring 300 x 300 [mm]
- 3) Measured on the scanning surface.

7. Reporting

7.1 General

All reports of non-destructive examinations to include the following items:

- 1) Date of testing
- 2) Names and qualification level of inspection personnel
- 3) Type of casting
- 4) Product number for identification
- 5) Grade of steel
- 6) Heat treatment
- 7) Stage of testing
- 8) Locations for testing
- 9) Surface condition
- 10) Test standards used
- 11) Calibration sensitivity
- 12) Results
- 13) Statement of acceptance / non-acceptance
- 14) Locations of reportable indications
- 15) Details of weld repairs including sketches.

7.2 In addition to the items listed in 7.1, reports of surface crack detection inspections are to include at least the following items:

- for liquid penetrant testing; the consumables used,
- for magnetic particle testing: method of magnetizing, test media and magnetic field strength.

7.3 In addition to the items listed in 7.1, reports of ultrasonic inspection should include at least the following items:

- flaw detector, probes, calibration blocks and couplant used.

8. Rectification of Defects

8.1 ***Defects and unacceptable indications must be repaired as indicated below:***

8.1.1 Defective parts of material may be removed by grinding or by chipping and grinding or by arc air-gouging. Thermal methods of metal removal should only be allowed before the final heat treatment. All grooves to have a bottom radius of approximately three times the groove depth and should be smoothly blended to the surface area with a finish equal to that of the adjacent surface.

8.1.2 Weld repairs should be suitably classified. Major repairs are those:

- where the depth is greater than 25% of the wall thickness or 25 [mm] whichever is less,
- where the total weld area on a casting exceeds 2% of the casting surface noting that where a distance between two welds is less than their average width, they are to be considered as one weld.

Major repairs require the approval of IRS before the repair is carried out. The repair is to be carried out before final furnace heat treatment.

8.1.3 Minor repairs are those:

- where the total weld area (length x width) exceeds 500 [mm²].

Minor repairs do not usually require the approval of IRS but to be recorded on a weld repair sketch as a part of the manufacturing procedure documents. These repairs should be carried out before final furnace heat treatment.

8.1.4 Cosmetic repairs are:

- all other welds.

Cosmetic repairs do not require the approval of IRS but to be recorded on a weld repair sketch. These repairs may be carried out after final furnace heat treatment but are subject to a local stress relief heat treatment.

8.1.5 Castings in carbon or carbon manganese steel may require pre-heating prior to welding and also a post weld stress relieving heat treatment depending upon their chemical composition and the dimensions and position of the weld repairs. Post weld heat treatment to be carried out at a temperature of not less than 550°C.

8.1.6 Castings subject to the removal of defects may be supplied without welding under the specific conditions:

- on un-machined surfaces where the depth of defect removal is not over 15 [mm] or 10% of wall thickness, whichever is less and the length of the removed part is not over 100 [mm].

8.1.7 Parts which are repaired should be examined by the same method as at initial inspection as well as by additional methods as recommended by the Surveyor.

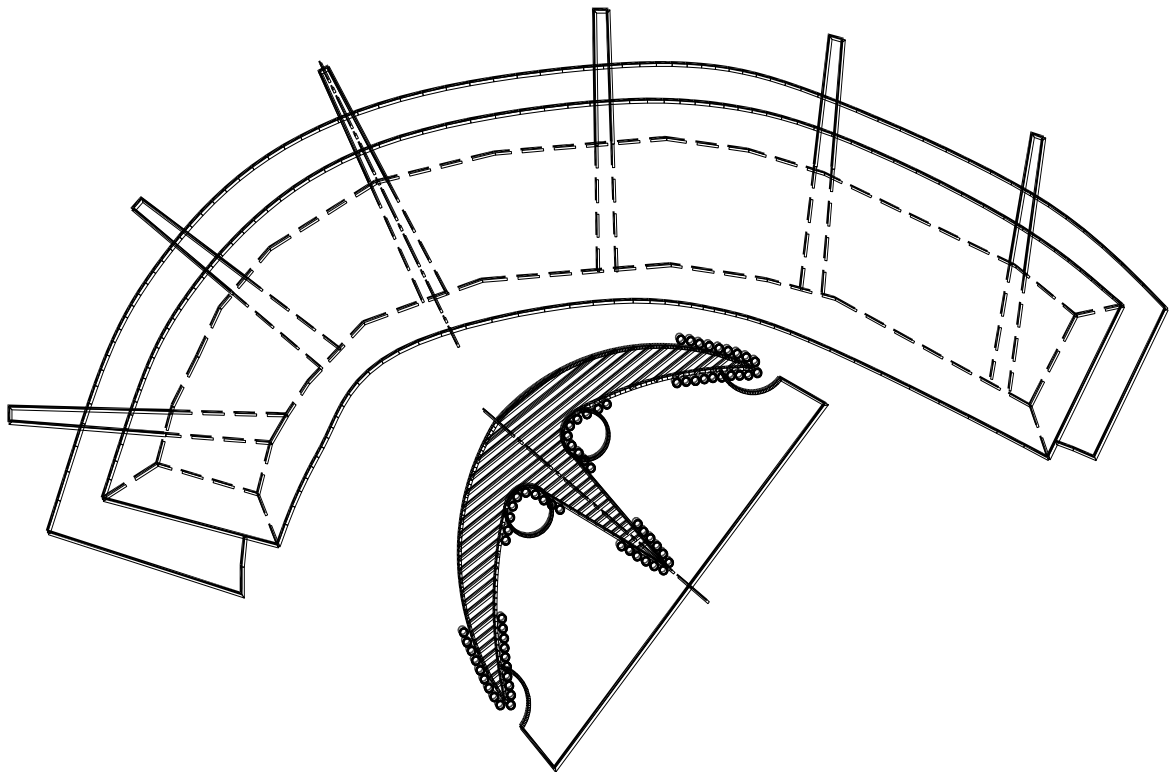

Notes : Location of non-destructive examination

- 1) All surfaces : Visual examination
- 2) Location indicated with (OOO) : Magnetic particle and Ultrasonic testing
- 3) The detailed extents of examinations and quality levels are given in Section 4 and 6.

Fig.1 : Stern Frame

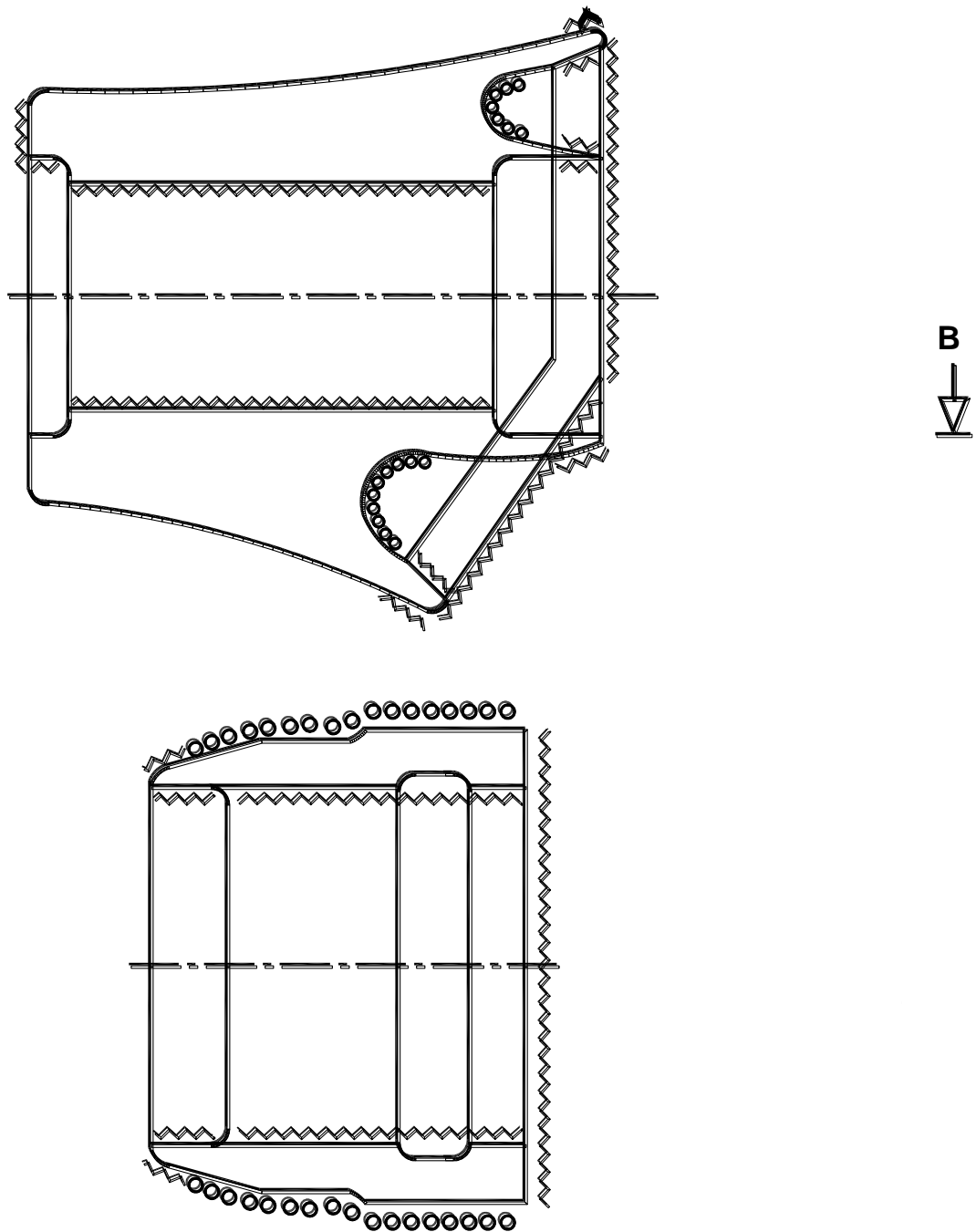

Notes : Location of non-destructive examination

- | | |
|---|---|
| 1) All surfaces : | Visual examination |
| 2) Location indicated with (OOO) : | Magnetic particle and
Ultrasonic testing |
| 3) Location indicated with (~~~~) : | Ultrasonic testing |
| 4) The detailed extents of examinations and quality levels are
given in Section 4 and 6. | |

Fig.3 : Stern Boss

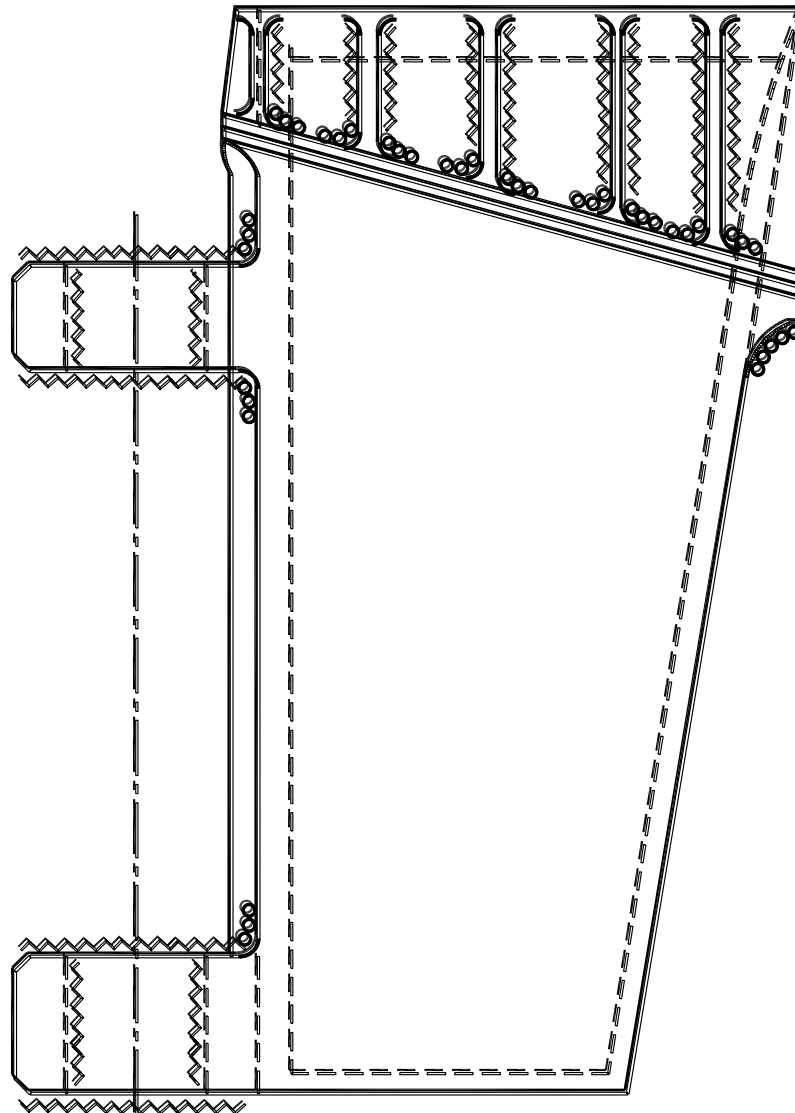

Notes : Location of non-destructive examination

- 1) All surfaces : Visual examination
- 2) Location indicated with (OOO) : Magnetic particle and Ultrasonic testing
- 3) Location indicated with (~~~~~) : Ultrasonic testing
- 4) The detailed extents of examinations and quality levels are given in Section 4 and 6.

Fig. 4 : Rudder Horn

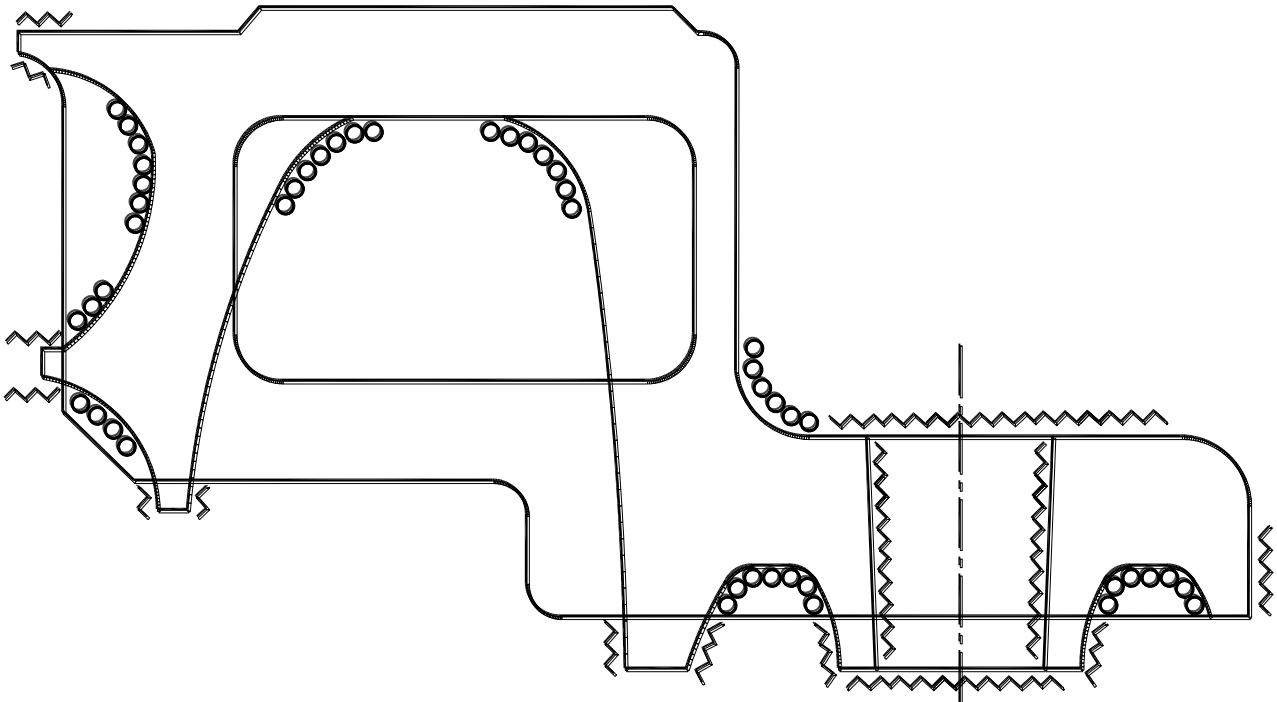

Notes : Location of non-destructive examination

- 1) All surfaces : Visual examination
- 2) Location indicated with (OOO) : Magnetic particle and Ultrasonic testing
- 3) Location indicated with (~~~~~) : Ultrasonic testing
- 4) The detailed extents of examinations and quality levels are given in Section 4 and 6.

Fig. 5 : Rudder (Upper Part)

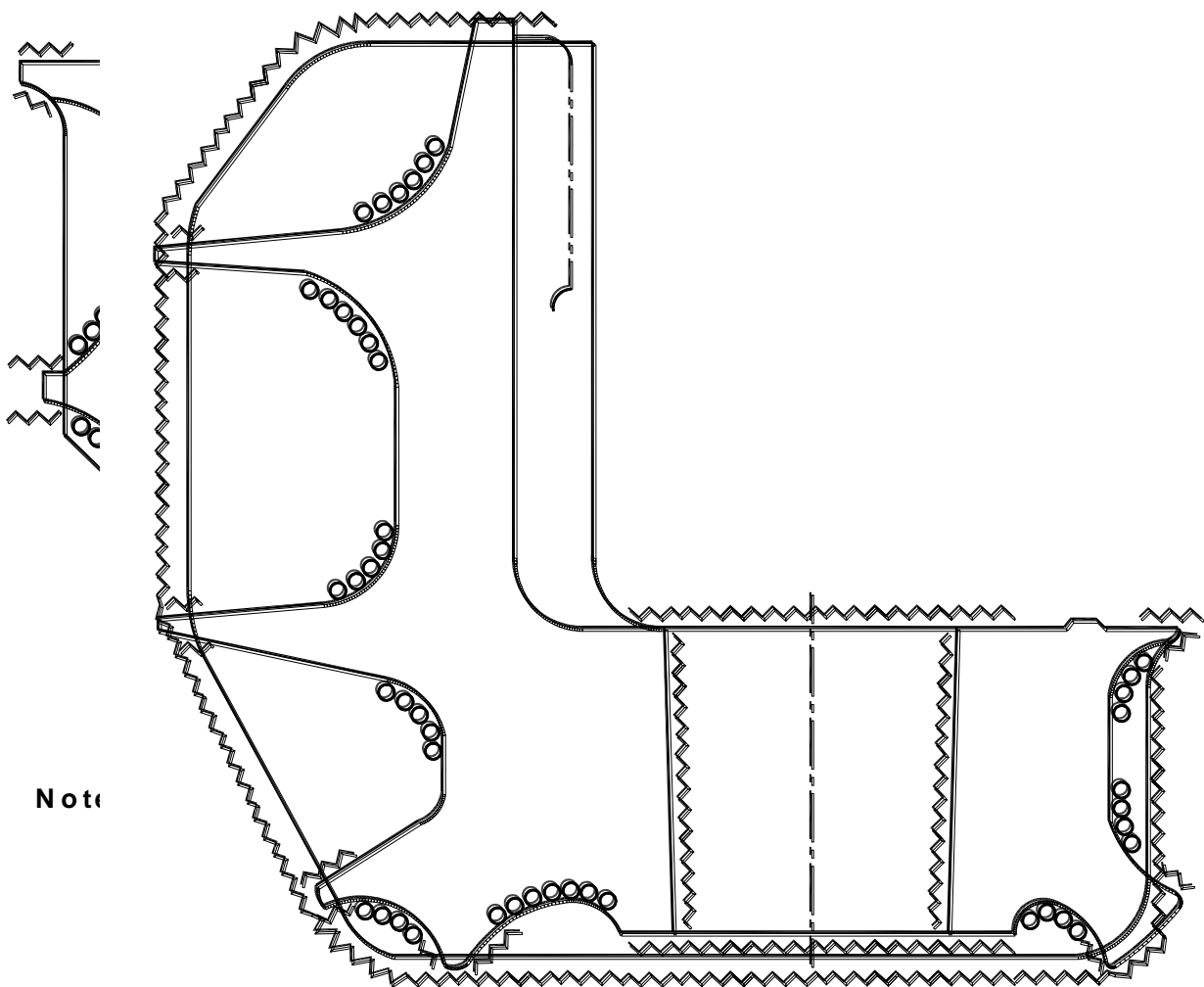

Notes : Location of non-destructive examination

- | | |
|--|---|
| 1) All surfaces : | Visual examination |
| 2) Location indicated with (OOO) : | Magnetic particle and
Ultrasonic testing |
| 3) Location indicated with (~~~~~) : | Ultrasonic testing |
| 4) The detailed extents of examinations and quality levels are given in Section 4 and 6. | |

Fig. 6 : Rudder (Lower Part)