

Guidelines on Ballast Water Management

2018



IRCLASS
Indian Register of Shipping

Introduction

Ballast water is important for safe and efficient operation of vessels; however it also leads to a variety of marine organisms being transported from one environment to another. Studies have revealed that invasion of such organisms causes harmful ecological, economic and health effects in the host environment.

To regulate the ballast water discharge from ships and to control the transfer of invasive species; The International Maritime Organization adopted the INTERNATIONAL CONVENTION FOR THE CONTROL AND MANAGEMENT OF SHIP'S BALLAST WATER AND SEDIMENTS (BWM Convention) in February 2004.

The purpose of the Convention is to prevent, minimize and ultimately eliminate the risk of introduction of Harmful Aquatic Organisms and Pathogens which use the ballast water as a hub.

These guidelines on Ballast Water Management have been developed by the Indian Register of Shipping, in order to assist the ship owners, ship designers and shipyards in implementing the Convention and in decision making.

The Guidelines are divided into **two** parts.

Part A – Ballast Water Management Convention and Ballast Water Treatment Solutions

Part B – Type Approval of BWMS

Part A

Ballast Water Management Convention and Ballast Water Treatment Solutions

Scope

The International Maritime Organization (IMO) has developed international legislation, the “International Convention for the Control and Management of Ships’ Ballast Water and Sediments”, to regulate discharges of ballast water and reduce the risk of introducing non-native species from ships’ ballast water.

In accordance with the Convention, the Ballast Water Management System (BWMS) installed on board a vessel is to be an IMO Member State type-approved and certified system and the installation of this system must have the prior approval/ acceptance of the vessel’s flag Administration. Each BWMS is tested, approved and certified in its standard product configuration. However there are design and engineering issues, as well as special considerations relating to Class requirements that will need to be addressed, as every ship is unique due to its design and operational profile.

The requirement for ballast water treatment has arisen from the requirements of regulation D-2 of the Convention. In response to this, a number of technologies have been developed to meet the requirements of the Ballast Water Management Convention and shipboard operation. The techno-economic considerations to be evaluated before selection of a suitable treatment system are many. Owners therefore face a complex task in choosing and installing the appropriate treatment systems particularly when past experience on operation and installation of such systems does not exist.

These guidelines have been prepared to summarize the current state of ballast water treatment regulations and available technologies in order to provide useful guidance to ship owners, operators, and builders in their decisions about suitable treatment options for new construction as well as existing ships

Table of Contents

- 1 The Issue
- 2 The Response
- 3 Ballast Water Management Regulations
 - 3.1 IMO Ballast Water Convention 2004
 - 3.2 The United States Coast Guard (USCG) Regulations
- 4 Ship Requirements (IMO BWM Convention, 2004)
 - 4.1 Ballast Water Management Options
 - 4.2 Sediment Management
 - 4.3 Ballast Water Management Plan (BWMP)
 - 4.4 Ballast Water Record Book (BWRB)
- 5 Compliance with IMO BWM Convention, 2004
 - 5.1 Planning for Compliance
 - 5.2 BWMS –Selection Criteria
 - 5.3 Procurement Specifications
 - 5.4 Information from Supplier
 - 5.5 Technical Considerations
 - 5.6 Evaluation Checklists –Factors impacting BWT Plant Selections
 - 5.7 Treatment Technology – Factors
 - 5.8 General Treatment Systems – factors
 - 5.9 Installations – Challenges
- 6 Surveys and Certification
 - 6.1 General
 - 6.2 Approval of Plans
 - 6.3 Installation
 - 6.4 Automation
 - 6.5 Electrical Equipment
 - 6.6 Guidance

1. The Issue

1.1 Water has been conventionally used as ballast to stabilize ships at sea. Ballast water is pumped- in to maintain safe and efficient operating conditions throughout a voyage, but it also poses a serious ecological, economic and health threat through the transfer of invasive aquatic species inadvertently carried in it. Ballast water contains a variety of organisms including bacteria and viruses and the adult and larval stages of the many marine and coastal plants and animals. While the vast majority of such organisms will not survive to the point when the ballast is discharged, some may survive and thrive in their new environment. These 'non-native species', if they become established, can have a serious ecological, economic and public health impact on the receiving environment.

2. The Response

2.1 The inadvertent transfer of harmful aquatic organisms and pathogens in the ballast water of ships has been determined to have caused a significant adverse impact to many of the world's coastal regions. In 1988, Canada and Australia first reported on invasive marine species in ballast waters. In response, in 1993, IMO adopted Res. A. 774(18) "Guidelines for preventing the introduction of unwanted aquatic organism and pathogens from ship's ballast water and sediments discharges". Later, The international maritime community, under the guidance of IMO developed "**International Conventions for the Control and Management of Ship's Ballast Water and Sediments, 2004**", (**Ballast Water Management Convention**), which was adopted at the diplomatic conference held at IMO Headquarters in London on 13 February 2004. This convention is aimed at preventing the introduction of unwanted aquatic organisms and pathogens through the discharge of ballast water and sediments. The convention has entered into force on 08 Sep 2017.

2.2 In addition to the IMO, other national bodies have introduced regulations in response to national concerns. The most influential of these is the United States Coast Guard (USCG) which has established both regulations and guidelines to prevent the introduction and spread of aquatic nuisance species. The US Coast Guard (USCG) published its final rule on Ballast Water Management for Control of Non-indigenous Species in Waters of the United States on 23 March 2012. **The USCG Regulations 33 CFR Part 151 and 46 CFR Part 162** entered into force on 21 June 2012 and apply to new ships constructed on or after 1 December 2013 as well as to existing ships by their first dry-docking after 2014 or 2016 depending on their BW capacity.

3. Ballast Water Management Regulations

3.1 IMO Ballast Water Convention, 2004

3.1.1 Overview

3.1.1.1 The International Conventions for the Control and Management of Ship's Ballast Water and Sediments, 2004 (hereinafter referred as the "BWM Convention 2004") consists of:

- Preamble,
- 22 Articles and
- an Annex (refer Table 3.1.1.1) which has :
 - 24 Regulations and
 - 2 Appendices.

3.1.1.2 Different measures may be taken by various countries to comply with the requirements of the convention, resulting in increased complexities. Therefore, IMO set out 14 guidelines, for the uniform implementation of the BWM convention. These are indicated in Table 3.1.1.2.

Table 3.1.1.1 Annex of BWM Convention 2004		
Section	Regulation	Title
A - General Provision	A-1	Definitions
	A-2	General Applicability
	A-3	Exceptions
	A-4	Exemptions
	A-5	Equivalent Compliance
B – Management and Control Requirements for Ships	B-1	Ballast Water Management Plan
	B-2	Ballast Water Record Book
	B-3	Ballast Water Management for Ships
	B-4	Ballast Water Exchange
	B-5	Sediments Management for Ships
	B-6	Duties of Officers and Crew
C – Special Requirements in Certain Areas	C-1	Additional Measures
	C-2	Warning Concerning Ballast Water Uptake in Certain Areas and related Flag State Measures
	C-3	Communication of Information
D – Standard for Ballast water Management	D-1	Ballast Water Exchange Standard
	D-2	Ballast Water Performance Standard
	D-3	Approval Requirement for Ballast Water Management System
	D-4	Prototype Ballast Water Treatment Technologies
	D-5	Review of Standards by the Organization
E – Survey and Certification Requirements for Ballast water Management	E-1	Surveys
	E-2	Insurance or Endorsement of a Certificate
	E-3	Insurance or Endorsement of by Another Party
	E-4	Form of the Certificate
	E-5	Duration and Validity of the Certificate
Appendix	Appendix I	Form of the Certificate
	Appendix II	Duration and Validity of the Certificate

Table 3.1.1.2 Ballast Water Management Guidelines		
G-1	Guidelines for Sediment Reception Facilities	Article 5
G-2	Guidelines for Ballast Water Sampling	Article 9, Article 12
G-3	Guidelines for Ballast Water Management Equivalent Compliance	Regulation A-5
G-4	Guidelines for Ballast Water Management and Development of Ballast Water Management Plans	Regulation A-2, Regulation B-1
G-5	Guidelines for Ballast Water Reception Facilities	Regulation B-3.6
G-6	Guidelines for Ballast Water Exchange	Regulation B-4, Regulation D-1
G-7	Guidelines for Risk Assessment under Regulation A-4 of the BWM Convention	Regulation A-4
	Code for approval of ballast water management systems (BWMS Code)	Regulation D-3
G-9	Procedure for Approval of Ballast Water Management Systems that make use of Active Substances	Regulation D-3.2
G-10	Guidelines for Approval and Oversight of Prototype Ballast Water Treatment Technology Programmes	Regulation D-4
G-11	Guidelines for Ballast Exchange Design and Construction Standards	Regulation D-1
G-12	Guidelines on Design and Construction to Facilitate Sediment Control on Ships	Regulation B-5.2
G-13	Guidelines for Additional Measures regarding Ballast Water Management including Emergency Situations	Regulation C-1
G-14	Guidelines on Designation of Areas for Ballast Water Exchange	Regulation B-4.2

3.1.2 Application of BWM Convention

3.1.2.1 Compliance Schedule

3.1.2.1.1 The BWM Convention 2004, has entered into force on 8 September 2017.

3.1.2.1.2 All ships are required to manage their ballast water on every voyage by either exchanging or treating it using an approved ballast water treatment system.

3.1.2.1.3 All ships of 400 GT and above are required to have on board an approved Ballast Water Management Plan and a Ballast Water Record Book, and to be surveyed and issued with an International Ballast Water Management Certificate. IRS as a Recognized Organization will issue the International Ballast Water Management Certificate on behalf of the Flag Administrations who are signatory to the Convention. For a ship flying the flag of country who is not a signatory to the Convention, a Statement of Compliance will be issued if requested by an Owner/Company or Shipyard.

Ship Constructed	Deadline for BWMS implementation
<p>1</p> <p>Before 8 September 2017</p>	<p>Vessels for which IOPP renewal survey does not apply</p> <p>By 8 September 2024</p>
<p>2</p>	<p>Vessels completed IOPP renewal survey on or after 8 September 2014 but prior to 7 September 2017</p> <p>By the completion date of first renewal survey associated with the IOPP Certificate on or after 8 September 2017</p>
<p>3</p>	<p>Vessels other than the above</p> <p>By the completion date of the second renewal survey associated with the IOPP Certificate on or after 8 September 2017 or the renewal survey associated with the IOPP Certificate on or after 8 September 2019, whichever comes first</p>
<p>4</p> <p>On or after 8 September 2017</p>	<p>All vessels</p> <p>By the completion date of the construction</p>
<p>1. The BWM Convention has entered into force on 08 September 2017.</p> <p>2. Refer to Regulation A-1.4 and A-1.5 for the definition of “Constructed”</p> <p>3. As per BWM.2/Circ.45, The Marine Environment Protection Committee, at its sixty-fourth session, agreed that new installation of ballast water management systems should not be treated as a "major conversion" as defined in regulation A-1.5 of the BWM Convention.</p> <p>4. As per BWM.2/Circ.45, The Marine Environment Protection Committee, at its sixty-fifth session, with respect to paragraph 5.2 of regulation A-1, agreed that a change of ship type should be considered to refer to a conversion that:</p> <p style="padding-left: 40px;">.1 substantially alters the dimensions or carrying capacity of the ship; or</p> <p style="padding-left: 40px;">.2 changes the type of cargo carried through a major alteration of the ship.</p>	

3.1.2.2 Applicability

3.1.2.2.1 The BWM Convention 2004, applies to vessels/installations, irrespective of size, including:

- FPSOs (Floating Production, Storage, Offloading)
- FSOs (Floating Storage, Offloading)
- Floating Craft
- Floating Platforms
- Submersibles

3.1.2.3 Exceptions (Article 3)

3.1.2.3.1 Ships not designed or constructed to carry Ballast Water or ships having permanent ballast water in sealed tanks on ships, that is not subject to discharge

3.1.2.3.2 Any warship, naval auxiliary or other ship owned or operated by a state and used, for the time being, only on government non-commercial service.

3.1.2.4 Exemptions (Regulation A-4)

3.1.2.4.1 Exemptions to any requirements to apply regulations B-3 or C-1 of the Convention may be granted by the Administrations, but only when they are

- .1 granted to a ship or ships on a voyage or voyages between specified ports or locations; or to a ship which operates exclusively between specified ports or locations;
- .2 effective for a period of no more than five years subject to intermediate review;
- .3 granted to ships that do not mix Ballast Water or Sediments other than between the ports or locations specified in Para 3.1.2.5.1.1; and
- .4 granted based on the Guidelines on risk assessment (G-7).

3.2.2.4.2 Exemptions granted pursuant to 3.1.2.5.1 will not be effective until after communication to IMO and circulation of relevant information to the Parties to the BWM Convention.

3.2.2.4.3 Any exemptions granted under Regulation A-4 are not to impair or damage the environment, human health, property or resources of adjacent or other States. Any State that the Party determines may be adversely affected is to be consulted, with a view to resolving any identified concerns.

3.2.2.4.4 Any exemptions granted under Regulation A-4 are to be recorded in the Ballast Water Record Book (BWRB).

3.2.2.4.5 Any exemption granted is valid for a maximum of five years subject to an intermediate review and provided the ship does not mix ballast water or sediments other than between the ports or locations specified in the exemption. However it should be noted that the exemptions can be withdrawn at any time by the issuing Administrations.

3.1.2.5 Equivalence Compliance

3.1.2.5.1 A simplified application of the Convention can be used in relation to recreation or competition or craft used primarily for search and rescue, less than 50 metres in length overall, and with a maximum Ballast Water capacity of 8 cubic metres through Regulation A-5 and Guidelines for ballast water management equivalent compliance (G3).

3.1.2.6 Prototype Ballast Water Treatment Technologies

3.1.2.6.1 For any ship that participates in a prototype testing program, the requirements of Regulation D-2 shall not apply until five years after the date the equipment was installed or five years after the date on which the ship would otherwise be required to comply with D-2, whichever is later.

3.1.2.7 Clarification on applicability of BWM Convention in specific cases:

3.1.2.7.1 Applicability of BWM convention to the water in the hopper area of hopper dredgers (BWM.2/Circ.32):

.1 Water in the hopper is considered as outboard water, i.e. the water is not taken aboard. Furthermore, the water is not used to control trim, list, draught or stresses of the ship. Water present in the hopper area is therefore not considered as ballast water and the provisions of the BWM Convention are not applicable to the water in the hopper area of hopper dredgers.

3.1.2.7.2 Applicability of the BWM convention to seawater loaded in ballast tanks of column stabilized units or in the preload tanks of self elevating units (BWM.2/Circ.46):

.1 Seawater loaded in ballast tanks of column stabilized units (CSUs) or in the preload tanks of self-elevating units' (SEUs) leg foundation, may be discharged, without management, at the same location provided that no mixing with unmanaged seawater or sediments from other areas has occurred. In case mixing has occurred or the location has changed, then the ballast water and sediments have to be managed as per the BWM Convention.

3.1.2.7.3 Applicability of BWM to drill water taken onboard OSVs

.1 Circular BWM.2/Circ.44 ("Options for ballast water management for Offshore Support Vessels in accordance with the BWM Convention") addresses methods of compliance for offshore support vessels (OSVs) and clarifies that drill water taken on board for the purpose of protecting low flash point liquid tanks, which is not discharged into the environment, is not subject to the requirements of the BWM Convention.

3.1.3 Ballast Water Treatment Standard

3.1.3.1 Regulation D-2 of the BWM Convention sets the standard that ballast water treatment systems must meet. Ballast water treatment systems must have a type approval certificate in compliance with the IMO Guidelines.

3.1.4 Approval

3.1.4.1 Technologies developed for ballast water treatment are subject to approval through specific IMO processes and testing guidelines. These are designed to ensure that such technologies meet the relevant IMO standards, are sufficiently robust, have minimal adverse environmental impact and are suitable for use in the specific shipboard environment.

3.1.4.2 Ballast water treatment systems are required to be tested against the following IMO guidelines:

- All systems:
 - Guidelines for Approval of Ballast Water Management Systems (BWMS Code).
- In addition, for systems employing active substances:
 - Procedure for Approval of Ballast Water Management Systems that make use of Active Substances (IMO Guideline G9)

3.1.4.3 Approval consists of both shore-based testing of a production model, to confirm that the D-2 discharge standards are met; and shipboard testing, to confirm that the system works in service.

3.1.4.4 The list of Type Approved Ballast Water Treatment Systems and other updates on the BWM Convention can be obtained on the IMO Website at the following link :

<http://www.imo.org/en/OurWork/Environment/BallastWaterManagement/Pages/BWMFAQ.aspx>

3.1.5 Port State Control

3.1.5.1 Once the BWM Convention enters into force, ships may be subject to inspections by port states to determine whether they comply with the BWM Convention's requirements. These inspections are limited to:

- verifying certification
- inspecting the ballast water record book
- sampling ballast water in accordance with the IMO's guidelines

3.2 The United States Coast Guard (USCG) Regulations

3.2.1 Overview

3.2.1.1 The US Coast Guard (USCG) published its final rule on Ballast Water Management for Control of Non-indigenous Species in Waters of the United States on 23 March 2012.

3.2.1.2 The USCG Regulations 33 CFR Part 151 and 46 CFR Part 162 entered into force on 21 June 2012 and apply to new ships constructed on or after 1 December 2013 as well as to existing ships by their first dry-docking after 2014 or 2016 depending on their BW capacity.

3.2.1.3 The United States has **not ratified** the BWM Convention and has established independent ballast water regulations

3.2.1.4 In the United States, ships must be in compliance with:

- USCG Ballast Water Regulations;
- US EPA Vessel General Permit;
- Individual State requirements

3.2.2 Application

3.2.2.1 Applicability

3.2.2.1.1 All ships calling at US ports and planning to discharge ballast water are to carry out ballast water exchange or treatment in addition to sediment management. However, ballast water exchange will only be allowed until the implementation dates for treatment systems shown in Table 3.2.2.1.1. The table indicates dates by which ships discharging ballast water in US waters are required to install a treatment system

3.2.2.2 Exemptions

3.2.2.2.1 The following vessels are exempt from ballast water management requirements, reporting requirements, and record keeping requirements:

- crude oil tankers engaged in coastwise trade; and
- vessels which operate exclusively within one 'Captain of the Port' (COTP) zone

3.2.2.2.2 The following vessels are exempt only from ballast water management requirements:

- seagoing vessels that operate in more than one COTP Zone, do not operate outside of the

Exclusive Economic Zone (EEZ), and are less than or equal to 1,600 gross register tons or less than or equal to 3,000 gross tons.

- non-seagoing vessels
- vessels that take on and discharge ballast water exclusively in one COTP zone.

3.2.2.3 Extensions

3.2.2.3.1 If the options given by the USCG are not practicably available despite all efforts, vessel owners can request an extension from the USCG to the implementation schedule. The availability of an Alternate Management System (AMS) does not prohibit a vessel owner from receiving an extension. The USCG regulations provide the process for requesting these extensions and when it can be documented. Extension requests must be submitted to the Coast Guard no later than 12 months before the scheduled implementation date.

3.2.3 Ballast Water Treatment Standard

3.2.3.1 USCG treatment discharge standard is the same as the IMO BWM Convention D-2 Standard

	Ballast Water Capacity	Date Constructed	Compliance Date
New Vessels	All	On or after 1 December, 2013	On Delivery
Existing Vessels	Less than 1.500 [m ³]	Before 1 December, 2013	First scheduled dry docking after 1 January, 2016
	1.500 – 5.000 [m ³]		First scheduled dry docking after 1 January, 2014
	Greater than 5.000 [m ³]		First scheduled dry docking after 1 January, 2016

3.2.4 Approval

3.2.4.1 The USCG requires that ballast water must be treated with a USCG type approved ballast water treatment system.

3.2.4.2 In addition, to avoid penalizing ships that have already fitted a treatment system approved by another flag administration, the USCG has introduced the Alternate Management System (AMS). Some important features of the AMS are given below:

- AMS are ballast water treatment systems which have been accepted for use in US waters by the USCG
- AMS is a temporary solution until the USCG type approved systems are available
- AMS approval does not necessarily mean that the system will achieve the USCG type approval
- A ship with an AMS installed can only use this system for a period of five years beyond the date when the ship would otherwise be required to comply with the USCG discharge standard
- The list of AMS approved systems can be found through US Department of Homeland Security's website at [https://homeport.usch.mil/ballast water](https://homeport.usch.mil/ballast%20water)

3.2.5 Port State Control

3.2.5.1 A report is required to be submitted to the USCG COTP 24 hours before arriving at a US port. The ship must provide the COTP with access to the vessel in order to take samples of ballast water and sediment; examine documents; and make other enquiries to assess compliance with USCG requirements.

4. Ship Requirements (IMO BWM Convention, 2004)

4.1 Ballast Water Management Options

4.1.1 Scope

4.1.1.1 The Convention defines two ballast water management standards:

- regulation D-1 specifies the ballast water exchange standard; and
- regulation D-2 specifies the ballast water performance standard.

4.1.2 Ballast Water Exchange (BWE)

4.1.2.1 Ballast water exchange is the process of exchanging coastal water, which may be fresh water, salt water or brackish water, for mid-ocean water. During the exchange process, biologically laden water taken on in the last port of call is flushed out of the ballast tanks with open ocean water, typically 200 nautical miles from the nearest land. Marine Biologists, have determined that marine organisms and pathogens are, in general, less numerous in the open ocean and, due to changes in the water's chemistry, temperature and salinity would be less likely to survive once they are discharged into the near shore receiving waters.

4.1.2.2 While the vast majority of vessels are capable of conducting ballast water exchange, and the procedures do not typically require any special structural modifications to most of the vessels in operation, it does present challenges for designers, builders, owners and operators. These challenges include over-pressurization or under-pressurization of tanks, longitudinal strength and transverse stability concerns, as well as maneuverability issues.

4.1.2.3 Acceptable methods for ballast water exchange are the sequential method, the flow-through method and the dilution method.

- *Sequential Method:* A process by which a ballast tank is first emptied and then refilled with replacement ballast water.
- *Flow-through Method:* A process by which replacement ballast water is pumped into a ballast tank, allowing water to flow through overflow or other arrangements. At least three times the tank volume is to be pumped through the tank.
- *Dilution Method:* A method by which replacement ballast water is filled through the top of the ballast tank with simultaneous discharge from the bottom at the same flow rate and maintaining a constant level in the tank throughout the ballast exchange operation. At least three times the tank volume is to be pumped through the tank.

4.1.2.4 Ballast Water Exchange Standard (Reg. D-1)

.1 Ships performing Ballast Water exchange are to do so with an efficiency of at least 95 percent volumetric exchange of Ballast Water.

.2 For ships exchanging Ballast Water by the pumping-through method, pumping through three times the volume of each Ballast Water tank shall be considered to meet the standard described above. Pumping through less than three times the volume may be accepted provided the ship can demonstrate that at least 95 percent volumetric exchange is met.

Ballast Water Exchange	
Regulation D-1	At least 95% of volumetric exchange or, if using the pumping through methods, three times the volume of each ballast water tank.
Regulation B-4	The Ballast Water exchange shall be conducted at least 200 miles from the nearest land and in water at least 200 metres in depth
Guideline G-6	Ballast Water Exchange
Guideline G-14	Designation of areas for ballast water exchange
Guideline G-11	Ballast water exchange design and conduction standards
MEPC. 163(56)	Ballast water exchange in Antarctic area

4.1.3 Ballast Water Treatment

4.1.3.1 The effectiveness of ballast water exchange varies and is dependent on the vessel type (design), exchange method (sequential, flow-through and dilution methods), ballasting system configuration, exchange location, weather conditions and vessel's trading pattern. For these reasons (and others), it has been determined that ballast water exchange does not provide adequate protective measures to prevent damage from organisms and pathogens carried in a vessel's ballast, even though exchange was considered to be acceptable as an interim solution.

4.1.3.2 The installation of ballast water management systems (or ballast water treatment systems), designed, reviewed, approved, installed and operated to satisfy an agreed-upon ballast water discharge performance standard has been determined by the international marine industry to provide a more effective means to prevent, minimize and ultimately eliminate the transfer of organisms and pathogens via vessel ballast discharge, when compared to ballast water exchange.

4.1.3.3 The BWM Convention does not provide specific requirements regarding the treatment methods. However, treatment equipment (systems) is to be type approved in compliance with the IMO guidelines. Moreover, technologies that make use of active substances are also to be approved by the relevant IMO committee (MEPC).

4.1.3.4 Ballast Water Performance Standard (Reg.D-2)

.1 Ships conducting Ballast Water Management in accordance with this regulation shall discharge less than 10 viable organisms per cubic metre greater than or equal to 50 micrometres in minimum dimension and less than 10 viable organisms per millilitre less than 50 micrometres in minimum dimension and greater than or equal to 10 micrometres in minimum dimension; and discharge of the indicator microbes shall not exceed the specified concentrations described in .2 below.

.2 Indicator microbes, as a human health standard, shall include:

- .1 Toxicogenic *Vibrio cholerae* (O1 and O139) with less than 1 colony forming unit (cfu) per 100 ml or less than 1 cfu per 1 gm (wet weight) zooplankton samples ;
- .2 *Escherichia coli* less than 250 cfu per 100 ml;
- .3 Intestinal Enterococci less than 100 cfu per 100 ml.

Note : cfu – colony forming unit

Ballast Water Treatment	
Regulations D-2	<p>Cap discharge for organisms:</p> <ul style="list-style-type: none"> • Less than 10 organisms per m³, for organisms ≥ 50 micrometres, • Less than 10 organisms per ml, for organisms between 10 and 50 microns, <p>Cap discharge of indicator microbes:</p> <ul style="list-style-type: none"> • Toxigenic <i>Vibrio cholerae</i>: 1 cfu per 100 ml • <i>Escherichia coli</i>: 250 cfu per 100 ml • Intestinal <i>Enterococci</i>: 100 cfu per 100 ml
BWMS Code	Code for approval of ballast water management systems
Guideline G-9	Approval of ballast water management systems that make use of active substances
Guideline G-10	Approval and oversight of prototype ballast water treatment technology programmes

4.1.3.5 Treatment Technologies

.1 The technologies currently available or being developed can generally be grouped under three broad categories based on their primary mechanism for rendering the organism inactive as: mechanical, physical and chemical. These groups and the more promising technologies related to each are described briefly below:

a) Mechanical Systems

- **Filtration** – Sediments and particles are removed with disk and screen filters during ballast intake. They are often self-cleaning with a back-flushing cycle. The waste stream is directed overboard back to the water source. These filtration systems create pressure drops and a reduced flow rate due to resistance in the filter elements and the self cleaning procedures.
- **Cyclonic separation** – Solid particles are separated from the water due to centrifugal forces. Only those particles with a specific gravity greater than that of water can be separated.
- **Electro-mechanical separation** – A flocculent is injected that attaches to organisms and sediment. Magnetic separation and filtration is used to remove the solid particles.

b) Physical Disinfection

- **Ultraviolet light** – UV radiation is used to attack and break down the cell membrane killing the organism outright or destroying its ability to reproduce. The effectiveness depends on the turbidity of the ballast water (i.e. the concentration of sediments) as this could limit the transmission of the UV radiation. UV lights are required to be maintained and power consumption needs to be considered.
- **Cavitation /Ultrasounds** – Venturi pipes or slit plates are used to generate cavitation bubbles and this high energy bubble creation and collapse results in hydrodynamic forces and ultrasonic oscillations, or high frequency noise, which disrupts the cell walls of organisms and effectively killing them.
- **De-oxygenation** – Various methods are used to remove the dissolved oxygen in the ballast water and replace it with inactive gases, such as nitrogen or other inert gas. Removing the oxygen not only kills the aerobic organisms but it can also have benefits for corrosion prevention provided that the oxygen content is maintained at

the correct levels. De-oxygenation can require a prolonged period in order to render the organisms and pathogens harmless to the receiving waters.

c) Chemical Treatment

- **Disinfecting biocides** – Pre-prepared or packaged disinfectants designed to be dosed into the ballast flow and kill the living organisms by chemical poisoning or oxidation. Typical biocides include chlorine, chloride ions, chlorine dioxide, sodium hypochlorite and ozone. Residual biocides in the ballast water must meet ballast discharge standards which may require neutralization techniques.
- **Electrolytic chlorination** – Electrical current is applied directly to the ballast water flow in an electrolytic chamber, generating free chlorine, sodium hypochlorite and hydroxyl radicals, causing electrochemical oxidation through the creation of ozone and hydrogen peroxide. This method is limited in effectiveness to seawater having a certain level of dissolved salt and could also create unwanted residuals. Types of chemical treatments include Active Substances or Preparations.

.2 The definitions given in the BWM Convention are as follows:

- **Active substance** – A substance or organism, including a virus or a fungus that has a general or specific action on or against harmful aquatic organisms and pathogens.
- **Preparation** – Any commercial formulation containing one or more active substances including any additives. This term also includes any active substances generated on board for the purpose of ballast water treatment and any relevant chemicals formed in the ballast water treatment system that make use of active substances to comply with the BWM Convention.

4.1.3.6 Ballast Water Treatment Systems – Important Characteristics

.1 Important characteristics of the treatment method for ballast water treatment systems, which are currently being offered in the market are given below. It is to be noted that some ballast water treatment systems which use chemical biocides or de-oxygenation may require additional treatment prior to the water being discharged into receiving waters.

Treatment Process	Treatment Method Characteristics			
	Method of Treatment	When Applied	Time for Lethality	Corrosion Potential
Chlorine Generation	Uses electrolytic cell to generate chlorine and bromine that act as biocides. Next, sodium sulfate neutralizes the ballast water prior to discharge. As long as free chlorine exists in the tank, biocide will be active so dosage can be adjusted to keep biocide always active.	At uptake and neutralize at discharge	Hours	High dosage levels promote steel corrosion
Chemical Application	Mix proprietary chemicals with ballast water in metered dosage rates at intake to kill living organisms. Chemicals degrade over time so ballast will be safe to discharge.	At uptake via eductors	24 hours	High dosage levels promote steel corrosion
Filtration & Radiation	Filtration of the incoming water, usually with self-cleaning 50 micron filters, in parallel with discharge of filtrate to the waters where intake takes place. Ballast water is exposed to a form of radiation, such as UV energy or other hydroxyl radical generator, to kill smaller organisms and bacteria.	At uptake for filter and UV and at discharge for UV	At treatment	No effect
De-Oxygenation	Mix inert gas generated on board with the ballast water, either by a venturi eductor or by bubbling from pipes in the tanks. This removes oxygen from the water and lowers pH, thereby killing the living organisms. This process requires the atmosphere in the ballast tank to be maintained in an inert condition.	At uptake for some systems and in tanks for others	4 to 6 days	Relatively less corrosive
Ozone Generation	Ozone is generated on board and acts as a biocide. It is applied during the ballast pumping process by educator either at uptake or discharge. It can be combined with filtration or other methods of treatment.	At uptake for some systems and at discharge for others	Up to 15 hours	Limited effects as ozone has short life. If treated at discharge, no effect.

4.1.3.7 Combination of Treatment Technologies

.1 Treatment technologies can be combined and differ in rate of application, holding time, power consumption and effects on other ship equipment or structures. A combination of different treatments can reduce the limitations of an individual technology. Therefore, many ballast water management systems (BWMS) use a combination of two or more technologies, e.g. filtration combined with UV, filtration combined with chemical injection/electro-chlorination, etc.

4.1.5 Other Methods

4.1.5.1 There may be other methods that can be used for the management of ballast water and those methods are also required to be approved by the Administration. IMO has developed guidance with

regard to the criteria to be used for such evaluations, which can be found in the *Procedure for approving other methods of ballast water management in accordance with regulation B-3.7 of the BWM Convention* (resolution MEPC.206(62)).

4.1.5.2 Other methods of ballast water management are to be approved in principle by the Marine Environment Protection Committee (MEPC) prior to approval by the Administration. The procedure ensures that other methods approved by an Administration are capable of at least achieving equivalence to the level of protection provided by the standards of the Convention with respect to the prevention of the transfer of harmful aquatic organisms and pathogens as required by regulations B-3.1 to B-3.5.

4.2 Sediment Management

4.2.1 Upon coming into force of the Convention, newly constructed vessels are to, (without compromising safety or operational efficiency), be designed and constructed with a view to minimize the uptake and undesirable entrapment of sediments, facilitate removal of sediments, and provide safe access to allow for sediment removal and sampling (Regulation B-5 of the BWM Convention 2004). The G-12 Guidelines are to be adhered to as far as practicable.

4.2.2 Both new and existing vessels however will be required to have procedures that can be implemented in the ballast water operation for sediment control. The recommendations given in the G-4 Guidelines, Part A, Section 1.3, are to be adhered to as far as practicable.

4.2.3 Details of the methods and operational procedures for the sediment management on board the vessel, including the disposal of sediments and the associated safety considerations, etc., are to be documented in the vessel's BWMP.

4.3 Ballast Water Management Plan (BWMP)

4.3.1 Each ship is to have on board and implement a Ballast Water Management Plan (BWMP). Such a plan is to be approved by the Administration/ RO on behalf of the Administration, if so authorized; taking into account Guidelines (G-4) developed by IMO. The BWMP is to be specific to each ship and is to at least:

- **detail** safety procedures for the ship and the crew associated with BWM as required by the Convention;
- **provide** a detailed description of the actions to be taken to implement the BWM requirements and supplemental BWM practices as set forth in the Convention;
- **detail** the procedures for the disposal of sediments:
 - at sea; and
 - to shore
- **include** the procedures for coordinating shipboard BWM that involves discharge to the sea with the authorities of the State into whose waters such discharge will take place;
- **designate** the officer on board in charge of ensuring that the plan is properly implemented and list his duties;
- **contain** the reporting requirements for ships provided for under the Convention; and
- **be written** in the working language of the ship. If this language is not English, French or Spanish a translation into one of these languages must be included.

4.3.2 The BWMP is to include training and education for ship's crew on BWM practices and the systems and procedures used on board the ship.

4.3.3 Regular review of the Plan by the owner, operator, or master is to be conducted to ensure that the information contained is accurate and updated. A feedback system is to be employed which will allow quick capture of changing information and incorporation of it into the Plan.

4.5.4 Changes to the provisions of the BWMP will need approval of the Administration.

Ballast Water Management Plan (BWMP)	
Regulation B-1	The BWMP is specific to each ship and shall include: <ul style="list-style-type: none"> • Safety procedures for the ship and crew with respect to the BWM • Actions and procedures to implement the BWM • Procedures for sediment disposal at sea and on-shore • Procedures for liaising effectively with authorities • The Officer coordinating shipboard BWM • The reporting requirements provided for under the Convention
Guideline G-4	BWM and development of BWMP

4.3.5 The following conventions, guidelines and rules are to be carefully considered, when applicable, for development of the BWMP:

Development of Ballast Water Management Plan (BWMP)	
BWM Convention	“International Convention for the Control and Management of Ship’s Ballast Water and Sediments”
Guideline G-4	Guidelines for Ballast Water Management and Development of Ballast Water Management Plans (G4)”
Guideline G-6	Guidelines for Ballast Water Exchange
BWMS Code	Code for approval of ballast water management systems
Guideline G-9	Procedure for approval of ballast water management systems that make use of active substances
Guideline G-10	Guidelines for approval and oversight of prototype ballast water treatment technology programmes
SOLAS Convention	International Convention for the Safety Of Life At Sea
MARPOL Convention	International Convention for the Prevention of Pollution from Ships

4.3.6 Ballast water management plan is required to be developed based on G4 guidelines adopted through MEPC.127(53). However where a BWMP has already been approved in accordance with resolution A.868(20) prior entry into force of BWM Convention, same will remain valid until the plan requires revision due to installation of a ballast water management system. A revised BWMP in accordance with the Convention will have to be approved in accordance with the latest IMO Guidelines (G-4) i.e. as per resolution MEPC.127(53).

4.4 Ballast Water Record Book (BWRB)

4.4.1 Each ship is to have a Ballast Water Record Book (BWRB) that may be in electronic form and which has to at least contain information specified in Appendix II to the Convention.

4.4.2 BWRB entries are to be maintained on board the ship for a minimum period of two years after the last entry has been made and thereafter in the Company’s control for a minimum period of three years.

4.4.3 All discharges of Ballast Water pursuant to Reg. A-3, A-4 or B-3.6 of the Convention, and/ or including accidental or exceptional discharges, not otherwise exempted by the Convention, are to be

recorded, without delay in the BWRB. The circumstances and the reason for the discharge are also to be indicated.

4.4.4 If exceptions or exemptions have been granted to the ship, the ship owner and operator is to ensure that they are properly documented and entered in the BWRB. It is to be noted that exceptions are situation specific, hence record keeping and communication is the only way of demonstrating compliance.

4.4.4 The BWRB is to be kept readily available for inspection at all times and, in the case of an unmanned ship under tow, may be kept on the towing ship.

Ballast Water Record Book (BWRB)	
Regulation B-2	Every ship shall keep a record of each Ballast Water operation in the form of a BWRB: <ul style="list-style-type: none">• In a paper book or as part of an electronic system• Contains at least the information specified in Appendix II• BWRB entries to be maintained onboard the ship for two years minimum and thereafter for three years in the control of the owner or manager of the ship• Readily available at all reasonable times

5. Compliance with IMO BWM Convention, 2004

5.1 Planning for Compliance

5.1.1 New Construction

5.1.1.1 Shipyards are to identify options for installing ballast water treatment systems in their new construction specifications – both within the construction programme or through retrofitting. This could involve providing system drawings to show how a selection of different treatment options might be fitted, ensuring that sufficient space has been allocated for retrofitting treatment systems if they are not included in the initial build. Piping connections are also to be fitted to ballast systems in preparation for retrofitting of the selected treatment equipment.

5.1.2 Existing ships

5.1.2.1 Operators will need to be aware of all modifications necessary to fit treatment systems to existing ships. It will be necessary to obtain schematic arrangements and equipment plans from the system supplier in order to develop a work programme. The work programme may alternatively be provided by the supplier, but the ship operator will still need to provide the ship's ballast water system plans, functional requirements and details of compartmental spaces where the equipment is to be fitted. Steps to be followed in selecting the ballast water treatment system are detailed in 5.2.

5.1.2.2 Recommended actions to plan for compliance with the BWM Convention are as given below:

5.2 BWMS – Selection Criteria

5.2.1 Type Approval

5.2.1.1 To install a Ballast Water Treatment System on board ship, it must be 'type approved' by the flag administration or a Recognised Organisation in accordance with the relevant IMO Guidelines. If the system uses an active substance, this will need to have received final approval from the IMO before type approval can be granted.

5.2.1.2 The list of Type Approved Ballast Water Treatment Systems and other updates on the BWM Convention can be obtained on the IMO Website at the following link :

<http://www.imo.org/en/OurWork/Environment/BallastWaterManagement/Pages/BWMFAQ.aspx>

5.2.1.3 More information on the procedures for type approval of BWMS is provided in Part B of these guidelines.

5.2.2 Capacity

5.2.2.1 All Ballast Water Treatment Systems have a 'total capacity rate' (TCR). This indicates how many cubic meters of ballast water the system can process each hour. A system with a TCR high enough to handle ship's ballast capacity and operational pumping rate is to be selected.

5.2.3 Space Requirements

5.2.3.1 System footprints range from approximately 0.25 m² to 145 m², depending on their TCR. Some are single units while others can be installed as separate components. Ballast Water treatment systems having separate components may be useful if a single space on board ship is not big enough or if access for bringing a single system on board is difficult.



Action Plan for achieving Compliance with Ballast Water Convention

5.2.4 Capital and operating costs

5.2.4.1 Ballast Water Treatment System installation is a big investment and could cost as much as \$2,000,000 depending on the manufacturer. As for operating costs, it depends on the type of system and starts from as little as a few dollars per 1,000 m³ of treated water. Many system suppliers quote operating costs below \$20 per 1,000 m³.

5.2.5 Power Requirements

5.2.5.1 Some systems have very high power requirements – as much as 220 kW per 1,000 m³ of treated water. Hence it is to be checked whether there will be a need to run another generator when the system is in operation or even install an additional generator set.

5.2.5.2 Another consideration is whether a spare breaker is available in the electrical distribution board to provide power to the Ballast Water Treatment System. If not, an alternative solution has to be arranged.

5.2.6 Integration with existing Ballast Water System

5.2.6.1 It is advantageous to integrate the alarms and controls for the treatment system with those for the ballast pumping system, so that both can be operated from all control panels.

5.2.7 Type of Process Technology employed

5.2.7.1 Overview of Treatment Technologies

.1 IMO defines ballast water treatment equipment as: "...the equipment which mechanically, physically, chemically or biologically processes either singularly or in combination to remove, render harmless or avoid the uptake or discharge of harmful organisms or pathogens. Ballast water treatment equipment may operate at the uptake or discharge of ballast water, during the voyage, or at a combination of these events."

5.2.7.2 Technical Challenges & System Combinations

.1 The treatment technologies differ in method and rate of application, scalability, holding time (required for kill rates and safe discharge), power requirements, effects on other ship systems or structure (corrosion), inherent safety and costs of operation. In many cases their efficacy varies with the conditions of the ballast water, flow rates, volume of water treated and holding time. There are also issues of whether treatment is done at intake, while being held on board, at discharge, or a combination of the three. For instance, filtration, separation and UV radiation are done during ballast. UV radiation is also used during de-ballasting. These systems are sized for the maximum flow rate in the ballast system. Conversely chemical biocides and de-oxygenation are usually applied to attain a certain concentration in the water in the ballast tanks.

.2 The efficacies of these systems do not depend so much on the flow rate of the pumps as the time the ballast is allowed to remain in the tanks to achieve the desired kill rate. Short voyages can be a problem for these technologies.

.3 Matching the treatment technology to the ship type, or more accurately the ballast system type, and vessel service is the key to designing a successful ballast water treatment system.

.4 To overcome the limitations of a particular technology many proposed treatment systems are based on a combination of two or more technologies. Although there are approved chemical disinfection only treatments, these are often combined with some form of pre-treatment to make them more effective for certain vessel or ballast conditions.

.5 The most prevalent system types are ones that combine mechanical separation/ filtration with UV radiation or chemical disinfection. The initial mechanical separation/ filtration is used to remove the larger organisms in order to increase the effectiveness of the secondary treatments.

5.2.8 Availability of consumables, spares and service support

5.2.8.1 It is important to be able to keep Ballast Water Treatment System operational at all times. If it stops working, there would be contravention of the Convention and ship could face fines or detention. Availability of spares, consumables and servicing support is to be ensured in all the areas where ship is trading.

5.2.9 Effect on Ballast Water Tank structure and Coatings

5.2.9.1 Corrosion and coating degeneration are two potential effects that system substances and processes may have on tanks. Hence assurance is required from the system manufacturer that tanks will not be adversely affected.

5.2.10 Time required for treatment to be effective

5.2.10.1 This is an important consideration depending on length of voyage and ballasting/ de-ballasting rate. For some Ballast Water Treatment plants, 24 hours of storing of ballast water in the ballast tanks after treatment can ensure effective disinfection to the Regulation D-2 and no re-growth of organisms were found in the treated water after 10 days. Extent of reduction in vessel's ballasting rate following installation of treatment system also needs to be considered i.e. detail of pressure drop and effect on ballast pump suction and delivery performance.

5.2.11 Health and Safety aspects for Crew

5.2.11.1 A number of different chemicals or chemical processes are employed in the ballast water treatment systems available, which are as follows:

- chlorination
- electrochlorination
- ozonation
- chlorine dioxide
- peracetic acid
- hydrogen peroxide
- menadine/vitamin K
- perchloric acid.

5.2.11.2 Some systems generate chemicals during the treatment process; for others, chemicals are required to be stored on board.

5.2.11.3 If chemicals are stored on board, the crew will require training on their use and handling. Suitable storage space for chemicals and proper ventilation are of paramount importance. The Safety Data Sheets for chemicals to be stored on board need to be consulted and where necessary the appropriate fire protection and extinction arrangements will need to be installed.

5.2.11.4 In the case of systems that generate chemicals during the treatment process, the crew will require training on the hazards associated with them. Advice on the storage and handling of chemicals is contained in the IMO Circular: BWM.2/Circ.20.

5.2.12 Ease of maintenance, calibration and water sampling

5.2.12.1 It needs to be ensured from suppliers that maintenance of Ballast Water Treatment plant, calibration of monitoring and measurement equipment and sampling of ballast water is easy.

5.2.13 Provision of Emergency bypass operation

5.2.13.1 To ensure the ballast water management system (BWMS) remains operational in the event of the treatment system failing, suitable by-passes or overrides are to be installed to protect the safety of the ship and personnel. The by-pass is to activate an alarm, and the by-pass event should be recorded by the control equipment.

5.2.14 Gas Safe

5.2.24.1 If ship is a tanker or gas carrier, and the system is going to be installed in a 'gas dangerous area' (i.e., in the cargo area), then system must be certified 'gas safe'.

5.3 Procurement Specifications

5.3.1 Points to be considered while preparing procurement specifications

5.3.1.1 In order to select a suitable system, ship operators will need to prepare a Procurement Specification for potential suppliers, which detail their technical requirements. This is to include the following information:

- The ballast water pump flow rates that the treatment system will be required to cope with (note: the treatment equipment capacity is to be greater than the ship's ballast rate to allow for an operating margin).
- A copy of the ballast system pipe work diagrams showing the connections, pumping capacities and valves.
- Compartment details for the installation of treatment equipment and storage of consumable materials.
- Power supply availability and routing for control cabling.
- Certification requirements
- Details of the ballast tank coatings

5.4 Information from Supplier

5.4.1 The following information (but not limited to) should be obtained from the suppliers as included in their offer

- Confirmation that their system has sufficient capacity to meet the ship's maximum ballast flow rates.
- The system's power consumption (excluding the ship's fitted ballast pumps) and any other electrical requirements.
- Types of technology employed in the system.
- The chemicals required and their consumption rates.
- Health and safety considerations in terms of working environment, handling and storage of chemicals.
- Protection systems for normal and emergency operation.
- Training requirements for system operation, calibration, monitoring and health and safety.
- The work plan for supply to ship, installation, commissioning and test.
- A statement of the effect that the treated ballast water will have on ballast tank coatings, including copies of relevant studies that support such claims.
- An estimate of the reduction in the vessel's ballasting rate following installation of the treatment system and a description of any mitigation measures. This is to include details of pressure drops and the effect that the introduction of the treatment equipment will have on ballast pump suction and delivery performance.

5.4.2 When short listing potential suppliers, in addition to price, operators are to consider: installation and commissioning costs; training requirements; estimated operating costs including consumables; maintenance requirements; operating experience; delivery lead times for supply and fitting; and any special docking requirements or ship modifications required for equipment installation.

5.5 Technical considerations

5.5.1 After technical data has been received from the suppliers, operators should carry out the following engineering checks:

- Ensure that existing auxiliary generators and control systems can cope with the additional power requirements (for some systems it may be necessary to upgrade generators).
- Check that treatment equipment can be easily integrated into existing ballast systems.
- Check the suitability of control requirements, including alarms and protective devices.
- Conduct a review of local versus remote operating systems and ease of integration with existing machinery controls.
- Assess ease of maintenance, calibration and ballast water sampling.
- Assess the need for venting or other measures for compartments where active substances (chemical or otherwise) are stored or at risk of escape.
- Review manufacturers' maintenance requirements to confirm which activities the ship's staff are required to perform, what spares and consumables would need to be carried, and what service requirements, if any, would have to be undertaken by the original equipment manufacturer (OEM).
- Assess how sediments will be managed.
- Ensure ballast tank gauging will not be affected by the ballast water treatment system.
- Ensure that the ballast water treatment system arrangements maintain the separation of ballast tanks located within 'gas safe' and 'gas dangerous' zones. In some cases, separate ballast water systems may be required for each zone. This applies to oil and chemical tankers.

5.6 Evaluation Checklists – Factors Impacting BWT Plant Selection

5.6.1 Owner Supplied Data

1. Ship type and capacity

- a. Ship type: high ballast dependent or low ballast dependent

2. Ballast water handling practices

- a. On average, how much ballast is loaded or discharged at any given port?
- b. What are the time constraints on ballast intake (how fast must it happen)?
- c. Maximum required flow rate for intake of ballast?
- d. What are the time constraints on ballast discharge (how fast must it happen)?
- e. Maximum required flow rate for discharge of ballast?
- f. Sediment build up in tanks (little, moderate, significant)
- g. Is treatment required for possible NOBOB (No Ballast on Board) condition?
- h. Minimum time ballast is held in a tank between port of calls?

3. Ballast water characteristics

- a. Are there freshwater ports encountered where ballast is taken in?
- b. Minimum salinity of brackish water encountered?
- c. Turbidity or silt content of port water (low, moderate, heavy)?

4. Vessel service characteristics

- a. Any unique service constraints or trading patterns regarding ballast use?
- b. Is there trade to special Ballast Water Treatment zones: California, Great Lakes, Australia, etc.?
- c. Does active ballast management allow zero ballast discharge in some/ all ports?

5. Ballast system characteristics

- a. What are the gravity intake/discharge practices?
- b. Can internal ballast transfer for trim, heel, bending moment control be easily accomplished?

5.7 Treatment Technology - Factors

5.7.1 Vendor Supplied Data

1. Treatment method

- a. Description of technology offered (all stages).
- b. For UV system: lamp type, required minimum intensity and water clarity?
- c. For chemical based treatment system:
 - (i) Required minimum dosage rate and minimum holding time ?
 - (ii) Neutralizing agents – how created, stored, dosed?
 - (iii) How long before safe to discharge?
 - (iv) Chemicals generated on board or supplied as preparations?
- d. For de-oxygenation:
 - (i) How much inert gas is required?
 - (ii) Minimum holding time?
 - (iii) Type of gas, fuel type and consumption to generate gas?

2. Treatment system capacity

- a. Overall treatment capacity (m³)
- b. Overall treatment rate (m³/hour)

3. Treatment system pressure drops

- a. Expected pressure drops added by treatment system to main ballast flow
- b. Quantity of ballast redirected for cleaning or sludge discharge
- c. Is gravity intake/discharge possible with this system?

4. Equipment size and space requirements

- a. Total space required for treatment equipment
- b. Size of largest single component
- c. Weight of largest single component
- d. Space required for maintenance (element removal, etc.)

5. Materials, equipment protection (IP rating) and hazardous spaces

- a. IP rating of components
- b. EX rating of components
- c. Any special risk assessments performed to date for hazardous space installations?

6. Power requirements

- a. Average and maximum power requirements and operating voltage
- b. Duration of maximum power consumption as function of ballast process

7. Impacts on ballast tank and pipe corrosion

- a. Is there published R&D available regarding the impact on tank and pipe corrosion rates?

8. Health and safety (handling, operation, maintenance)

- a. Quantity of treatment chemicals needed (per ton of ballast water treated)
- b. For active substances: a copy of the MEPC final approval with recommendations.
- c. For active substances: Material Safety Data Sheets

5.8 General Treatment System - Factors

5.8.1 Vendor Supplied Data

- 1. Proven efficacy and official approvals**
 - a. Copy of Type Approval Certificate issued by, on behalf of, a Government
 - b. System limitations or operating guidelines from Type Approval process
- 2. Vendor qualifications and reputation**
 - a. Annual production capacity of manufacturer?
 - b. Which components are custom made or incorporate new/ novel technology?
 - c. How many units have been built at the factory to be used for this installation?
 - d. Client referrals for previously installed systems
- 3. Maintenance requirements and system reliability**
 - a. How many units of similar capacity have been installed?
 - b. What is average duration of operating experience per unit?
 - c. What is standard maintenance protocol?
 - d. What is expected service life?
- 4. Simple operation: control and monitoring**
 - a. Type of remote control system included
 - b. Ease of connection to primary control and monitoring system
- 5. Life cycle costs**
 - a. Estimated power consumption for normal ballast operations?
 - b. Fuel consumption expected for inert gas generation?
 - c. Cost of consumables (chemicals, lamps, filter elements)?
 - d. Expected frequency of resupply of consumables for planned system size?
 - e. What major components are most likely to need replacement within 10, 15, 20, 25 years? What is their cost?

5.9 Installation - Challenges

5.9.1 Owner Supplied Data

- 1. Intake/ discharge isolation: cross-contamination**
 - a. Can piping installation options provide good contamination protection?
 - b. Can intake and discharge pumps be isolated and dedicated to that service?
- 2. Sampling and in-service testing**
 - a. Is there adequate space and facilities for sampling and testing?
- 3. Maintaining ballasting flexibility**
 - a. Can the treatment system options selected provide full ballast flexibility?
- 4. Other Relevant Matters required to be considered for installation of BWTS**
 - a. Is there space for all system components and ballast connections?
 - b. What are the access openings and routes for bringing in new treatment system components?
 - c. What are the access needs during system operation and maintenance?
 - d. Are switchboard modifications required?
 - e. Are control system modifications required?

6 Surveys and Certification

6.1 General

6.1.1 Surveys are to be performed to ensure that the Ballast Water Management plan and any associated structure, equipment, systems, fitting, arrangements and material or processes are maintained and comply with the requirements of the Convention (Section E of the Convention). Although the provisions of the Convention apply to all ships (except as set up by Article 3 of the Convention), the survey and certification requirements apply only to ships of 400 GT and above, except floating platforms, FSU and FPSO.

6.1.2 Certificates or endorsements will be issued indicating completion of the survey. Before the ship is put in service an initial survey is required to verify that the ballast water management plan and the ship's structure, equipment, systems, fittings, arrangements and material or processes comply fully with the requirements of the Convention, following which the certificate will be issued. Ships are also subject to annual surveys, which must occur within three months before or after each anniversary date. The intermediate survey will take place within three months before or after the second or third anniversary date, and shall take place of one of the annual surveys as mentioned above. The certificate must also be renewed at a full renewal survey, at a date specified by the Administration but not exceeding every five years, to verify full compliance (structure, equipment, systems, fittings, arrangements and material or processes) with the applicable requirements of the Convention.

6.1.3 In addition to the requirements contained in BWM Convention (2004), requirements of this section will be applied to the installation of Ballast Water Management Systems.

6.2 Approval of Plans

6.2.1 Hull plans showing the foundation and attachments to ship's structure for each component of the BWMS are to be submitted and approved. These plans are to clearly indicate the scantlings and details of welding.

6.2.2 Machinery plans showing the installation design of the BWMS on the ship including location, piping and electrical details/drawings, general arrangement and layout, installation and equipment plans are to be submitted and approved before proceeding with the installation. Plans are to include applicable arrangements for hazardous areas acceptable to IRS, if applicable.

6.2.3 Following plans and documentation are to be submitted for approval

1. General arrangement drawings of the BWMS. Installation arrangement drawings on the ship including location and layout.
2. Ballast piping system drawings including Layout, filling arrangement and booklet of construction details of piping system.
3. Location of ballast water sampling facilities
4. Electrical circuit drawings and main power cable drawings
5. Power calculation document Including electrical load analysis
6. Control, monitoring and safety system documentation especially where the controls and monitoring of the BWMS have been connected to or integrated with the ship's control and monitoring system(s)
7. Local instrumentation arrangement plan

8. Structural plans Showing installation details of attachment, supports and foundations of principal components of the BWMS
9. Hazardous area plan
10. Storage tanks and day tanks containing chemicals and preparations used to treat ballast water including complete piping details of filling, drain system, vents, drip trays, and safety precautions, etc.
11. Leakage detection system and safety features associated with the generation of toxic or flammable gases. Safety features include sensor, alarms and shutdown settings, etc. together with proper suitable certification. Schematic plans detailing arrangement and location of sensor are to be provided.
12. Safety assessment documentation, where applicable For BWMS that employs active substances and preparations; include arrangement, handling and safety plans of auxiliary systems for the treatment system, as applicable.
13. Ballast water management plan (BWMP) BWMP is specific to the ship and in a standard format per G4 Guidelines
14. BWMS operating and safety manual specific to the actual installation onboard the ship
15. Shipboard function test plan for sea or quay trial Function test of the installed BWMS at the sea trial or quay trial in the presence of attending Surveyor; function test plan per paragraph 5.1.9 of G8 Guidelines

6.2.4 Following plans and documentation are to be submitted for information:

1. Arrangement and capacity of ballast tanks and pumps
2. List of electrical equipment in hazardous area
3. Safety documentation for hazardous chemicals In recognized industry format, such as MSDS, CHRIS Code, Cole-Palmer
4. Ballast water record book specific to the ship

6.3 Installation

6.3.1 General requirements pertaining to the installation:

6.3.1.1 All valves, piping fittings and flanges are to comply with the relevant requirements of *Part 4 Chapter 2, Rules and Regulations for the Construction and Classification of Steel ships*. In addition, special consideration can be given to the material used for this service with the agreement of IRS.

6.3.1.2 The BWMS is to be provided with by-pass or override arrangement to effectively isolate it from any essential ship system to which it is connected.

6.3.1.3 The BWMS is to be operated at a flow rate within the Treatment Rated Capacity (TRC) range specified in the Type Approval Certificate (TAC) issued by the Flag Administration.

6.3.1.4 Where a vacuum may occur in the ballast line due to the height difference, a suitable protection means is to be provided, e.g. P/V valves or breather valves, and their outlets are to be led to safe area on open deck.

6.3.1.5 Electric and electronic components are not to be installed in a hazardous area unless they are of certified safe type for use in the area. Cable penetrations of decks and bulkheads are to be sealed when a pressure difference between the areas is to be maintained.

6.3.1.6 Where the operating principle of the BWMS involves the generation of a dangerous gas, the following requirements are to be satisfied:

.1 Gas detection equipment is to be fitted in the spaces where dangerous gas could be present, and an audible and visual alarm is to be activated both locally and at the BWMS control station in the event of leakage. The gas detection device is to be designed and tested in accordance with IEC 60079-29-1 or recognized standards acceptable to IRS.

.2 The ventilation line of a space where dangerous gas could be present is to be led to a safe area on open deck.

.3 The arrangements used for gas relieving, i.e. degas equipment or equivalent, are to be provided with monitoring measures with independent shutdown. The open end of the gas relieving device is to be led to a safe area on open deck.

6.3.1.7 Ballast piping, including sampling lines from ballast tanks considered as hazardous areas, is not to be led to an enclosed space regarded as a safe area, without any appropriate measures, except ships carrying liquefied gases in bulk. However, a sampling point for checking the performance of BWMS, for ballast water containing dangerous gas, may be located in a safe area provided the following requirements are fulfilled:

.1 The sampling facility (for BWMS monitoring/control) is to be located within a gas tight enclosure (hereinafter, referred to as a 'cabinet'), and the following (i) through (iii) are to be complied.

i) In the cabinet, a stop valve is to be installed in each sample pipe.

ii) Gas detection equipment is to be installed in the cabinet and the valves specified in i) above are to be automatically closed upon activation of the gas detection equipment.

iii) Audible and visual alarm signals are to be activated both locally and at the BWMS control station when the concentration of explosive gases reaches a pre-set value, which should not be higher than 30% of the lower flammable limit (LFL) of the concerned product.

.2 The standard internal diameter of sampling pipes is to be the minimum necessary in order to achieve the functional requirements of the sampling system.

.3 The measuring system is to be installed as close to the bulkhead as possible, and the length of measuring pipe in any safe area is to be as short as possible.

.4 Stop valves are to be located in the safe area, in both the suction and return pipes close to the bulkhead penetrations. A warning plate stating "Keep valve closed when not performing measurements" is to be posted near the valves. Furthermore, in order to prevent backflow, a water seal or equivalent arrangement is to be installed on the hazardous area side of the return pipes.

.5 A safety valve is to be installed on the hazardous area side of each sampling pipe.

6.3.1.8 For the spaces, including hazardous areas, where toxicity, asphyxiation, corrosivity or reactivity is present, these hazards are to be taken into account and additional precautions for the ventilation of the spaces and protection of the crew are to be considered.

6.3.2 Additional Requirements for tankers

6.3.2.1 Hazardous area classification is to be in accordance with IEC 60092-502.

6.3.2.2 For tankers carrying flammable liquids having a flashpoint not exceeding 60°C or products listed in the IBC Code having a flashpoint not exceeding 60°C or cargoes heated to temperature above their flashpoint and cargoes heated to temperature within 15°C of their flashpoint. In general, two independent BWMS may be required – i.e. one for ballast tanks in hazardous areas and the other for ballast tanks in non-hazardous areas.

6.3.2.3 The interconnection of ballast piping between hazardous areas and in non-hazardous areas may be accepted if an appropriate isolation arrangement is applied. Means of appropriate isolation are as follows:

- .1 Two screw down check valves in series with a spool piece, or

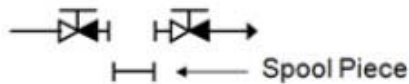

- .2 Two screw down check valves in series with a liquid seal at least 1.5 m in depth, or

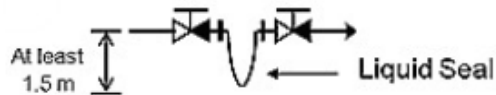

- .3 Automatic double block and bleed valves and a non-return valve

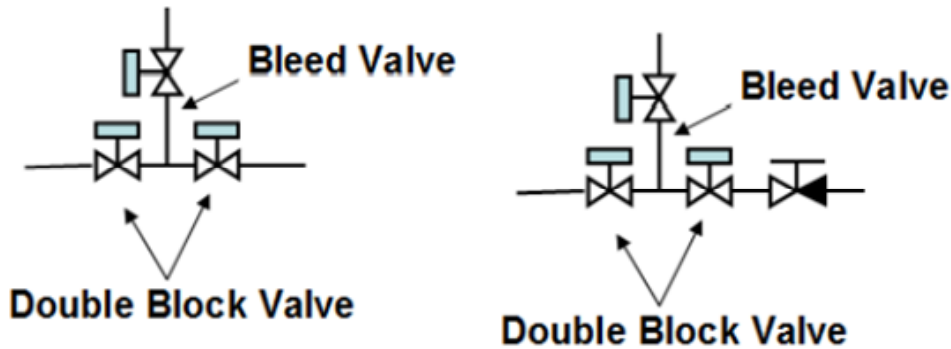

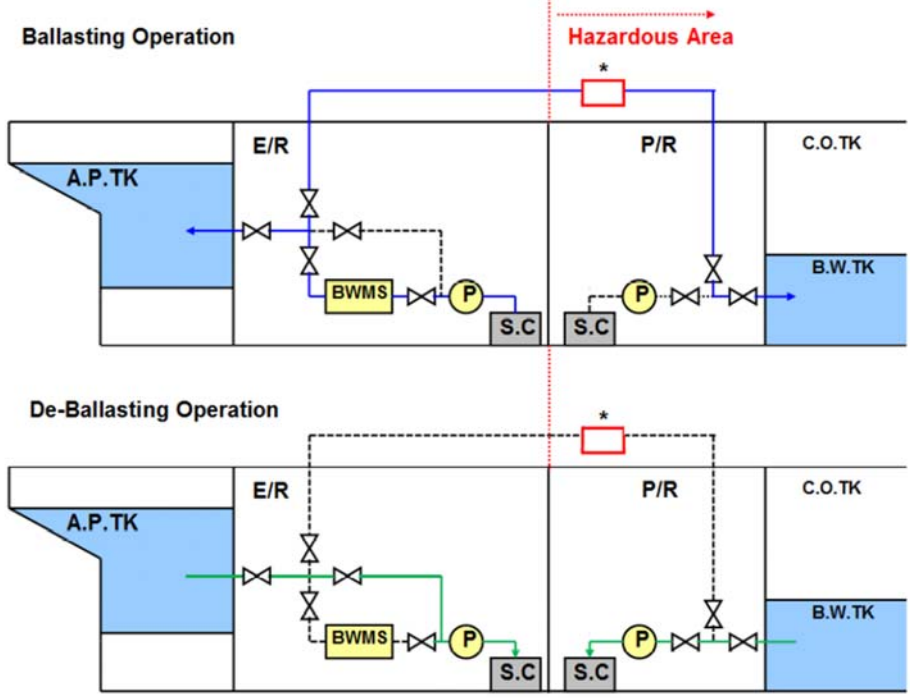

6.3.2.4 Examples of appropriate isolation arrangements are shown below. Isolation arrangements are to be fitted on the exposed deck in the hazardous area. Also, ballast water originating from a hazardous area is not to discharge into a non-hazardous area, except as given in 6.3.1.7.

BWMS which does not require after-treatment

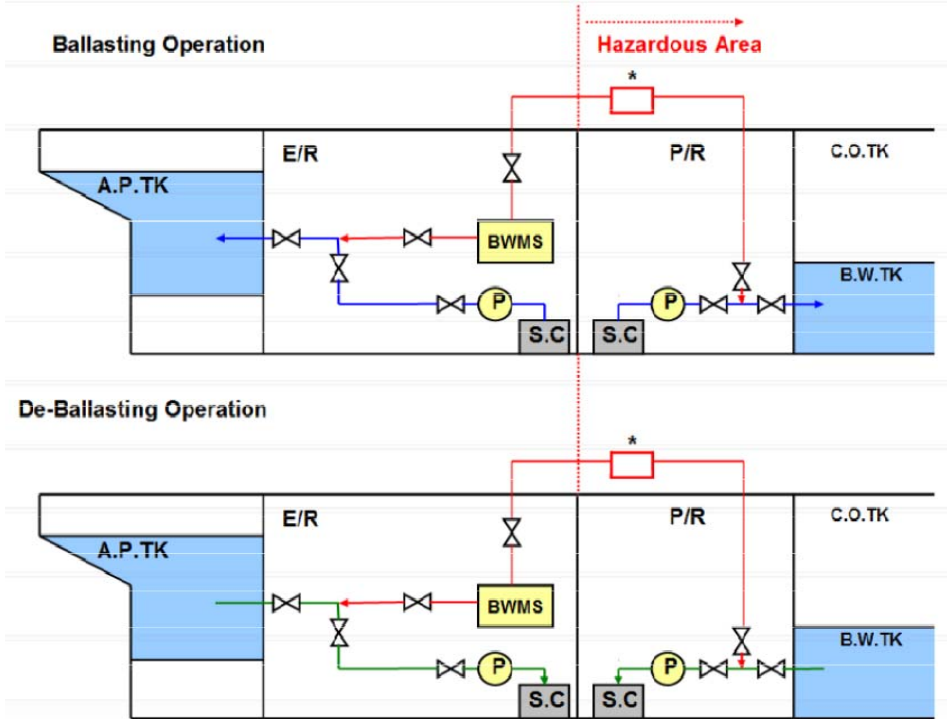

BWMS which require after-treatment (Injection type)



*  : Appropriate Isolation Means: Two (2) screw down check valves in series with a spool piece or a liquid seal, or automatic double block and bleed valves

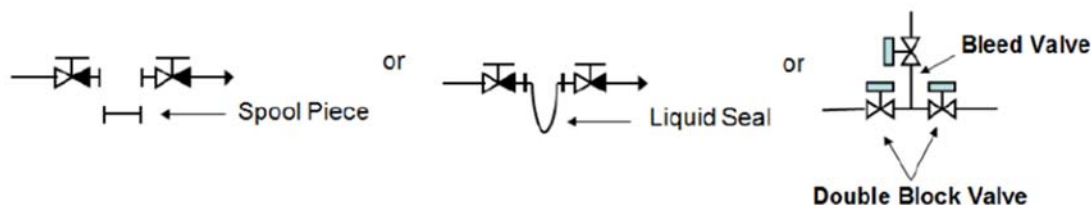

6.3.3 Ventilation

6.3.3.1 BWMS not in hazardous areas:

- .1 A BWMS that does not generate dangerous gas is to be located in an adequately ventilated area.
- .2 A BWMS that generates dangerous gas is to be located in a space fitted with a mechanical ventilation system providing at least 6 air changes per hour or as specified by the BWMS manufacturer, whichever is greater.

6.3.3.2 BWMS in hazardous areas:

- .1 A BWMS, regardless of whether or not it generates dangerous gas, is to be located in a space fitted with mechanical ventilation complying with relevant requirements, e.g. IEC60092-502, IBC Code, IGC Code, etc.

6.3.4 Special requirements:

6.3.4.1 The length of pipe and the number of connections are to be minimised in piping systems containing dangerous gases/liquids in high concentration. The following requirements are also to be satisfied:

- .1 Pipe joints are to be of welded type except for connections to shut off valves, double walled pipes or pipes in ducts equipped with mechanical exhaust ventilation. Alternatively it is to be demonstrated that risk of leakage is minimized and the formation of toxic or flammable atmosphere is prevented.
- .2 Location of the piping system is to be away from heat sources and protected from mechanical damage.

6.3.4.2 For BWMS using chemical substances, handling procedures are to be in accordance with the Material Safety Data Sheet and BWM.2/Circ.20, and the following measures are to be taken as appropriate:

- .1 The materials used for the chemical storage tanks, piping and fittings are to be resistant to such chemicals.
- .2 Chemical storage tanks are to have sufficient strength and be constructed such that maintenance and inspection can be easily performed.
- .3 Chemical storage tank air pipes are to be led to a safe area on open deck.
- .4 An operation manual containing chemical injection procedures, alarm systems, measures in case of emergency, etc, is to be kept onboard.

6.3.4.3 Where the BWMS is installed in an independent compartment, the compartment is to be:

- .1 Provided with fire integrity equivalent to other machinery spaces.

.2 Positioned outside of any combustible, corrosive, toxic, or hazardous areas unless otherwise specifically approved.

6.3.4.4 A risk assessment may be conducted to ensure that risks, including but not limited to those arising from the use of dangerous gas affecting persons on board, the marine environment, the structural strength or integrity of the ship are identified.

6.4 Automation

6.4.1 In case of any by-pass or override operation of BWMS, an audible and visual alarm is to be given and these events are to be automatically recorded in control equipment. The valves in the by-pass line which trigger the by-pass operation are to be remote-controllable by control equipment or fitted with open/close indicator for automatic detection of the by-pass event.

6.5 Electric Equipment

6.5.1 General

6.5.1.1 The requirements applicable to explosion proof electric equipment, generator capacities etc. related to the system depend on the installed location of the ballast water treatment system.

6.5.1.2 The relevant electric equipment is to have a degree of protection (IP grade) suitable for the installed location in accordance with the Rule requirements.

6.5.1.3 The total electrical load of a BWMS is to be such that under all anticipated ballasting or de-ballasting operating conditions, the electrical generating capacity installed on the vessel is to be adequately demonstrated by an electrical load analysis.

6.5.2 Special Requirements for Tankers, Ships carrying dangerous chemicals in bulk and Ships carrying liquefied gases in bulk

6.5.2.1 When electric equipment of the ballast water treatment system is to be installed in a hazardous area of a tanker, ship carrying dangerous chemicals in bulk, or a ship carrying liquefied gases in bulk, the equipment are to comply with the relevant requirements of IRS Rules.

6.6 Guidance

6.6.1 Installation of BWMS in container

6.6.1.1 Consideration is to be given to the following :

- (a) Structural strength and damage stability.
- (b) In case of any failure compromising the proper operation of the BWMS, audible and visual alarm signals should be given in all stations from which ballast water operations are controlled. (G-8, CI 4.3)
- (c) If chemicals are used for BWMS and the chemical tank is installed in container, the chemical for which temperature limitation is required should be managed appropriately.
- (d) In case, gases (ex. H₂) are generated in the process of treatment for BWMS, the tightness of container and ventilation system should be considered.

6.6.2 Installation of BWMS in an independent enclosed compartment

.1 If the BWMS is installed in an independent enclosed compartment, the structural fire protection category of the said compartment should be considered.

.2 This compartment may be treated as "Other machinery space", similar to the ballast pump room.

6.6.3 Installation location of chemical tank

.1 In principle, the limitations imposed for approval described in G-8 and G-9 are to be adhered to.

.2 Separate safety measures may be demanded by IRS depending on the hazards associated with the chemicals.

6.6.4 Installation position of backwash line

.1 Under BWM Convention, installation backwash line on downstream of G-2 sampling point may be accepted.

Part B

Type Approval of BWMS

Scope

This Part describes the steps and procedures involved in Type Approval of Ballast Water Management Systems for use on board ships essentially for the control of the transfer of harmful aquatic organisms and pathogens through ships' Ballast Water and Sediments.

Indian Register of Shipping can act on behalf of the Administration if authorized as Recognized Organization (RO) to carry out the activities on its behalf and comply with these guidelines.

Table of Contents

- 1 Overview of BWMS
 - 1.1 Background
 - 1.2 Applicability of the Convention
 - 1.3 Requirements of the Convention
 - 1.4 What is BWMS?
 - 1.5 BWMS Type Approval Regulations
 - 1.6 Methodology
- 2 PROCEDURE FOR EVALUATION OF BWMS SYSTEM – Type approval of ballast water management system not using Active Substance
 - 2.1 Pre-Test Evaluation
 - 2.2 Test and performance specifications for approval of BWMS
 - 2.3 Specification for environmental testing for approval of BWMS
 - 2.4 Reporting
 - 2.5 Validation of System Design Limitations
 - 2.6 Reporting of test results
 - 2.7 Issuance of Type Approval Certificate
- 3 PROCEDURE FOR EVALUATION OF BWMS SYSTEM – Type approval of ballast water management system using Active Substance
 - 3.1 Basic Approval
 - 3.2 Final Approval
 - 3.3 Type Approval
 - 3.4 Notification of Approval
- 4 Miscellaneous
 - 4.1 Definitions
 - 4.2 Appendix - A
 - 4.3 Appendix - B
 - 4.4 References

1 Overview of BWMS

1.1 Background

1.1.1 The inadvertent transfer of harmful aquatic organisms and pathogens in the ballast water of ships has caused a significant adverse impact to many of the world's coastal regions. The international maritime community, under the auspices of the International Maritime Organization (IMO) has developed the "International Conventions for the Control and Management of Ship's Ballast Water and Sediments, 2004", (Ballast Water Management Convention), which is aimed at preventing the introduction of unwanted aquatic organisms and pathogens through the discharge of ballast water and sediments. The BWM convention has entered into force on 08 September 2017.

1.2 Applicability of the Convention

1.2.1 The Ballast Water Management Convention applies to vessels registered in a country which is party to the Convention and to those vessels registered in other countries when operating in the waters of a country which is party to the Convention.

1.3 Requirements of the Convention

1.3.1 In accordance with **Article 4** of the Convention, every ship has to exercise Control of the Transfer of Harmful Aquatic Organisms and Pathogens through Ships' Ballast Water and Sediments. To meet the requirements of the convention, a vessel needs to:

- Conduct Ballast water exchange or
- Be fitted with an approved ballast water management system(BWMS)

The convention requires the ballast water exchange method to be done away with in a phased ~~out~~ manner and a type approved 'ballast water management system' to be installed onboard.

1.4 What is BWMS?

1.4.1 Ballast Water Management System (BWMS) is any system which processes ballast water such that it meets or exceeds the Ballast Water Performance Standard of the Convention. The BWMS includes Ballast Water Treatment Equipment, all associated Control Equipment, Monitoring Equipment and Sampling Facilities.

1.5 BWMS Type Approval Regulations

1.5.1 Ballast water management systems are required to meet the standards of regulation D-2 and the conditions established in regulation D-3 of the Convention. These Guidelines serve to evaluate the safety, environmental acceptability, practicability and biological effectiveness of the systems designed to meet these standards and conditions. These Guidelines contain recommendations regarding the design, installation, performance, testing environmental acceptability and approval of ballast water management systems.

1.5.2 Regulation D-2 stipulates that ships, fitted with BWMS, meeting the requirements of the Convention by meeting the ballast water performance standard must discharge (Refer Table 1):

- .1 Less than 10 viable organisms per cubic meter greater than or equal to 50 micrometers in minimum dimension;
- .2 Less than 10 viable organisms per milliliter less than 50 micrometers in minimum dimension and greater than or equal to 10 micrometers in minimum dimension; and

- .3 Less than the following concentrations of indicator microbes, as a human health standard:
- .1 Toxicogenic *Vibrio cholerae* (serotypes O1 and O139) with less than 1 Colony Forming Unit (cfu) per 100 milliliters or less than 1 cfu per 1 gramme (wet weight) of zooplankton samples;
 - .2 *Escherichia coli* less than 250 cfu per 100 milliliters; and
 - .3 Intestinal Enterococci less than 100 cfu per 100 milliliters.

Table 1

Constituent	Discharge Limitation
Organisms \geq 50 μ m	< 10 viable organisms per m ³ of ballast water
50 μ m > Organisms \geq 10 μ m	< 10 viable organisms per ml of ballast water
Indicator Microbes	
Toxicogenic <i>Vibrio cholera</i> (serotypes O1 and O139)	< 1 colony-forming unit (cfu) per 100 ml 1 cfu/1g (Wet weight)
<i>Escherichia coli</i>	< 250 cfu per 100 ml
Intestinal Enterococci	< 100 cfu per 100 ml

1.6 Methodology

1.6.1 There are two methods available to meet the D2 standards depending on the technology deployed by the BWMS equipment manufacturer:

- Method I where no active substances are involved
- Method II where active substances are used

2 PROCEDURE FOR EVALUATION OF BWMS SYSTEM - Type Approval of ballast water management systems not using Active Substances

Procedure

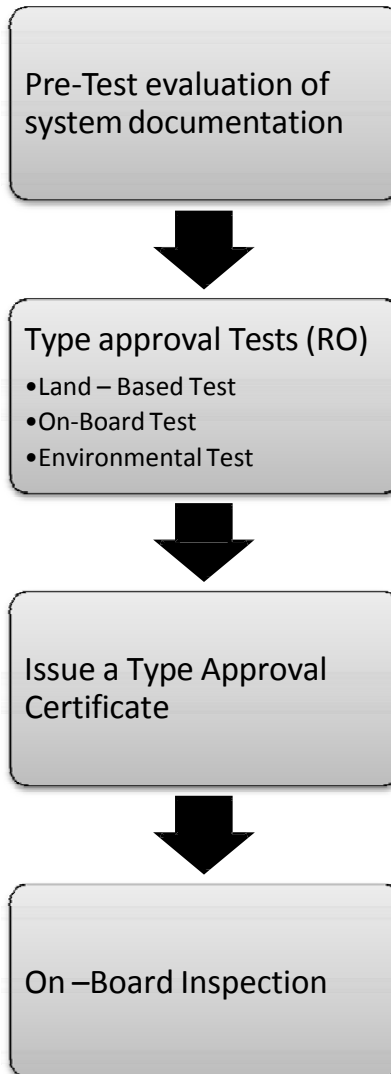

Test Items	Test Standards
On-Board Test	<ul style="list-style-type: none"> To comply with D-2 requirements after repeating ballast water suction, storage, discharge process thrice
Land-Based Test	<ul style="list-style-type: none"> Test Cycle <ul style="list-style-type: none"> > 5 times /each cycle (PSU) Minimum 2 cycles (Total 10 times) Capacity of control tank and Ballast tank should be greater than 200 cu.m Time of Sampling: 3 times shortly before /after ballast water treatment
Environmental Test	<ul style="list-style-type: none"> Vibration test Temperature test Moisture test IP test Power variation test Incline test EMC test

2.1 Pre-Test evaluation

A Pre-Test evaluation is to be done of at least the following system documentation provided by the manufacturer/developer for two primary purposes: evaluating the readiness of the BWMS for undergoing approval testing and evaluating the manufacturer's proposed SDL (System Design Limitation) and validation procedures.

2.1.1 Documentation

A Pre-Test evaluation is to be done of at least the following system documentation provided by the manufacturer/developer.

- .1 a BWMS technical specification, including at least:
 - .1 a description of the BWMS, treatment processes it employs and details of any required permits;
 - .2 adequate information including descriptions and diagrammatic drawings of the pumping and piping arrangements, electrical/electronic wiring, monitoring system, waste streams and sampling points. Such information should enable fault finding;
 - .3 details of major components and materials used (including certificates where appropriate);
 - .4 an equipment list showing all components subject to testing including specifications, materials and serial numbers;
 - .5 an installation specification in accordance with manufacturers installation criteria requirements for the location and mounting of components, arrangements for maintaining the integrity of the boundary between safe and hazardous spaces and the arrangement of the sample piping;
 - .6 information regarding the characteristics and arrangements in which the system is to be installed, including scope of the ships (sizes, types and operation) for which the system is intended. This information may form the link between the system and the ship's Ballast Water Management Plan; and
 - .7 a description of BWMS side streams (e.g. filtered material, centrifugal concentrate, waste or residual chemicals) including a description of the actions planned to properly manage and dispose of such wastes;
- .2 the operation, maintenance and safety manual, including at least:

- .1 instructions for the correct operation of the BWMS, including procedures for the discharge of untreated water in the event of malfunction of the ballast water treatment equipment;
 - .2 instructions for the correct arrangement of the BWMS;
 - .3 maintenance and safety instructions and the need to keep records;
 - .4 troubleshooting procedures;
 - .5 emergency procedures necessary for securing the ship;
 - .6 any supplementary information considered necessary for the safe and efficient operation of the BWMS, e.g. documentation provided for approval under the Procedure for approval of ballast water management systems that make use of Active Substances (G9) (resolution MEPC.169(57)); and
 - .7 calibration procedures;
- .3 information on any hazard identification conducted to identify potential hazards and define appropriate control measures, if the BWMS or the storage tanks for processing chemicals could emit dangerous gases or liquids;
- .4 information regarding environmental and public health impacts including:
- .1 identification of potential hazards to the environment based on environmental studies performed to the extent necessary to assure that no harmful effects are to be expected;
 - .2 in the case of BWMS that make use of Active Substances or Preparations containing one or more Active Substances, the dosage of any Active Substances used and the maximum allowable discharge concentrations;
 - .3 in the case of BWMS that do not make use of Active Substances or preparations, but which could reasonably be expected to result in changes to the chemical composition of the treated water such that adverse impacts to receiving waters might occur upon discharge, the documentation shall include results of toxicity tests of treated water as described in paragraph 2.19 of this annex; and
 - .4 sufficient information to enable the test organization to identify any potential health or environmental safety problems, unusual operating requirements (labour or materials), and any issues related to the disposal of treatment by-products or waste streams;
- .5 information regarding SDL including:
- .1 the identification of all known parameters to which the design of the BWMS is sensitive;
 - .2 for each parameter the manufacturer shall claim a low and/or a high value for which the BWMS is capable of achieving the Performance Standard of regulation D-2; and
 - .3 the proposed method for validating each claimed SDL shall be set out, together with information on the source, suitability and reliability of the method;
- .6 a software change handling and revision control document including all software changes introduced to the system after the pre-test evaluation. These shall be done according to a change handling procedure ensuring traceability. Therefore, the manufacturer is to present a procedure describing how changes are to be handled and how revision control is maintained. As a minimum for a modification request, the following types of information are to be produced and logged:
- .1 reason for modification;
 - .2 specification of the proposed change;
 - .3 authorization of modification; and
 - .4 test record;
- .7 functional description including a textual description with necessary supporting drawings, diagrams and figures to cover:
- .1 system configuration and arrangement;
 - .2 scope of supply;
 - .3 system functionality covering control, monitoring, alarm and safety functions;
 - .4 self-diagnostics and alarming functionalities; and
 - .5 safe states for each function implemented.

The documentation may include specific information relevant to the test set-up to be used for land-based testing according to this Code. Such information is to include the sampling needed to ensure proper functioning and any other relevant information needed to ensure proper evaluation of the efficacy and effects of the equipment. The information provided is to also address general compliance with applicable environment, health and safety standards during the type-approval procedure.

2.1.2 Readiness evaluation

2.1.2.1 During the readiness evaluation, it is to be ensured that each technical specification set out in section

4 of BWMS Code has been met, other than those that will be assessed during later testing.

2.1.2.2 The readiness evaluation is to examine the design and construction of the BWMS to determine whether there are any fundamental problems that might constrain the ability of the BWMS to manage ballast water as proposed by the manufacturer, or to operate safely, on board ships.

2.1.2.3 It is to be ensured that adequate risk assessments including the implementation of preventative actions have been undertaken relating to the safe operation of BWMS.

2.1.2.4 As a first step the manufacturer is to provide information regarding the requirements and procedures for installing, calibrating and operating (including maintenance requirements) the BWMS during a test. This evaluation would help the test organization to identify any potential health or environmental safety problems, unusual operating requirements (labour or materials), and any issues related to the disposal of treatment by-products or waste streams.

2.1.2.5 The test facility is to have a procedure to deal with deviations that occur prior to testing and an evaluation process which includes an assessment and validation process to address any unforeseen deviations that may occur during testing. Deviations from the testing procedure are to be fully reported.

2.1.2.6 During the readiness evaluation the major components of the BWMS are to be identified. Major components are considered to be those components that directly affect the ability of the system to meet the Performance Standard described in regulation D-2. Upgrades or changes to major components are not to take place during type approval testing. A change to a major component requires a new submission of the test proposal and would involve a new evaluation and repeating of the land-based and shipboard tests.

2.1.2.7 Replacements of non-major components of equivalent specification (independently approved to a recognized and equal operational standard) may be allowed during type approval. Replacements of non-major components during testing are to be reported.

2.1.2.8 Upgrades of the BWMS that relate to the safe operation of that system may be allowed during and after type approval and are to be reported. If such safety upgrades directly affect the ability of the system to meet the standard described in regulation D-2, they are to be treated as a change of a major component, as per paragraph 1.10 above.

2.1.2.9 The evaluation is to identify consumable components in the BWMS. Replacement of like-for-like consumable components may be allowed during type approval testing and all replacements are to be reported.

2.1.3 System Design Limitation evaluation

2.1.3.1 The SDL evaluation is to assess the basis for the manufacturer's claim that the SDL include all known water quality and operational parameters to which the design of the BWMS is sensitive and that are important to its ability to achieve the Performance Standard described in regulation D-2.

2.1.3.2 The suitability and reliability of the methods proposed are also to be evaluated for validating the claimed low and/or high values for each SDL. These methods may include tests to be undertaken during land-based, shipboard or bench-scale testing and/or the use of appropriate existing data and/or models.

2.2 Test and performance specifications for approval of BWMS

2.2.1 The Administration/RO decides the sequence of land-based and shipboard testing. The BWMS used for testing would be verified by the Administration/RO to be the same as the BWMS described under Para. 2.1 above with major components as described in the documentation submitted in accordance with paragraphs 2.1.1.1.3 and 2.1.1.1.4 above.

Quality Assurance and Quality Control Procedures

2.2.2 The test facility is to demonstrate its competency in conducting valid type approval tests in two ways:

- .1 by having implemented a rigorous quality control/quality assurance program, approved, certified and audited by an independent accreditation body, or to the satisfaction of the Administration/RO; and
- .2 by demonstrating its ability to conduct valid test cycles with appropriate challenge water, sample collection, sample analysis and method detection limits.

It is the responsibility of the Administration, or its RO, to determine the acceptability of the test facility.

2.2.3 The test facility's quality control/quality assurance program shall consist of:

- .1 a Quality Management Plan (QMP), which addresses the quality control management structure and policies of the testing body (including subcontractors and outside laboratories);
- .2 a Quality Assurance Project Plan (QAPP), which defines the methods, procedures, and quality assurance and quality control (QA/QC) protocols used by the test facility for testing BWMS in general. It identifies the test team members, and it includes all relevant standard operating procedures (SOPs), typically as appendices; and
- .3 a Test/Quality Assurance Plan (TQAP), that provides specific details for conducting a test of a given BWMS at a given site and time. The TQAP includes detailed plans for commissioning the BWMS, the experimental plan, decommissioning, and reporting the results. The TQAP identifies all organizations involved in the test and includes the BWMS manufacturer's documentation and performance claims. The TQAP also identifies the data to be recorded, operational and challenge parameters that define a valid test cycle, data analyses to be presented in the verification report and a schedule for testing. Appropriate statistical distributions shall be considered and used to analyze data.

2.2.4 The test facility performing the BWMS tests is to be independent. It is not to be owned by or affiliated with the manufacturer or vendor of any BWMS, or by the manufacturer or supplier of the major components of that equipment.

Avoiding sampling bias

2.2.5 The sampling protocol is to ensure organism mortality is minimized, e.g. by using appropriate valves and flow rates for flow control in the sampling facility, submerging nets during sampling collection, using appropriate sampling duration and handling times, and appropriate concentrating methodology. All methods to avoid sampling bias is to be validated to the satisfaction of the Administration/RO.

Shipboard tests

2.2.6 A shipboard test cycle includes:

- .1 the uptake of ballast water of the ship;
- .2 treatment of the ballast water in accordance with paragraph 2.2.8.4 by the BWMS;
- .3 the storage of ballast water on the ship during a voyage; and
- .4 the discharge of ballast water from the ship.

2.2.7 Shipboard testing of BWMS is to be conducted by the test facility, independent of the BWMS manufacturer, with the system being operated and maintained by the ships' crew as per the operation, maintenance and safety manual.

Success criteria for shipboard testing

2.2.8 In evaluating the performance of BWMS installation(s) on a ship or ships, the following information and results are to be supplied to the satisfaction of the Administration/RO:

- .1 test plan to be provided prior to testing;
- .2 documentation that an in-line BWMS is of a capacity to reflect the flow rate of the ballast water pump for the TRC of the BWMS;
- .3 documentation that an in-tank BWMS is of a capacity to reflect the ballast water volume that it is intended to treat within a specified period of time;
- .4 the amount of ballast water tested in the test cycle on board is to be consistent with the normal ballast operations of the ship and the BWMS is to be operated at the TRC for which it is intended to be approved;
- .5 documentation showing that the discharge of each valid test cycle was in compliance with regulation D-2. For a test to be valid, the uptake water for the ballast water to be treated is to contain a density of viable organisms exceeding 10 times the maximum permitted values in regulation D-2.1;
- .6 sampling regime and volumes for analysis:
 - .1 for the enumeration of viable organisms greater than or equal to 50 μm or more in minimum dimension:
 - .1 influent water is to be collected over the duration of uptake as one time-integrated sample. The sample shall be collected as a single, continuous sample or a composite of sequential samples, e.g. collected at intervals during the beginning, middle and end of the operation. The total sample volume is to be at least 1 m³. If a smaller volume is validated to ensure representative sampling of organisms, it may be used
 - .2 treated discharged water is to be collected as one time-integrated sample over the

- duration of discharge from the tank(s). The sample may be collected as a single, continuous sample or a composite of sequential samples, e.g. collected throughout the beginning, middle and end the operation. The total sample volume is to be at least 3 m³;
- .3 if samples are concentrated for enumeration, the organisms are to be concentrated using a mesh with holes no greater than 50 µm in the diagonal dimension. Only organisms greater than 50 µm in minimum dimension are to be enumerated; and
- .4 the full volume of the sample is to be analyzed unless the total number of organisms is high, e.g. 100. In this case, the average density may be extrapolated based on a well-mixed subsample using a validated method;
- .2 for the enumeration of viable organisms greater than or equal to 10 µm and less than 50 µm in minimum dimension:
- .1 influent water is to be collected over the duration of uptake as one, time-integrated sample. The sample is to be collected as a single, continuous sample or a composite of sequential samples, e.g. collected at intervals during the beginning, middle and end of the operation. A sample of at least 10 L is to be collected, and a fraction may be subsampled for transport to the laboratory, provided it is representative of the sample and is a minimum of 1 L. A minimum of three 1 mL subsamples are to be analyzed in full to enumerate organisms;
- .2 treated discharged water is to be collected as one time-integrated sample over the duration of discharge from the tank(s). The sample may be collected as a single, continuous sample or a composite of sequential samples, e.g. collected throughout the beginning, middle and end of the operation. A sample of at least 10 L is to be collected, and a fraction may be subsampled for transport to the laboratory, provided it is representative of the sample and is a minimum of 1 L. A minimum of six 1 mL subsamples shall be analyzed in full to enumerate organisms;
- .3 the sample may not be concentrated for analysis unless the procedure is validated. Only organisms greater than 10 µm and less than 50 µm in minimum dimension shall be enumerated; and
- .4 the full volume of the sample is to be analyzed unless the total number of organisms is high, e.g. 100. In this case, the average density may be extrapolated based on a well-mixed subsample using a validated method;
- .3 for the evaluation of bacteria:
- .1 for the influent and discharge samples, the minimum 10 L sample referred to in paragraphs 2.2.8.6.2.1 and 2.2.8.6.2.2, or another sample at least 10 L in volume and collected in a similar manner is to be used, a subsample of minimum 1 L may be transferred to a sterile container for analysis;
- .2 a minimum of three subsamples of appropriate volume taken from the 1 L subsample described above is to be analyzed for colony forming units of bacteria listed in regulation D-2; and
- .3 the toxicogenic test requirements is to be conducted in an appropriately approved laboratory. If no approved laboratory is available, the analysis method may be validated to the satisfaction of the Administration.
- .7 the test cycles including invalid test cycles is to span a period of not less than six months;
- .8 three consecutive test cycles in compliance with regulation D-2 are to be performed. Any invalid test cycle does not affect the consecutive sequence;
- .9 the six-month shipboard test period starts and ends with the completion of a successful test cycle or invalid test cycle that meets the D-2 standard. The three consecutive and valid test cycles that are required in paragraph 2.2.8.8 above is to be suitably separated across the six-month period;
- .10 the source water for test cycles is to be characterized by measurement of salinity, temperature, particulate organic carbon, total suspended solids and dissolved organic carbon; and
- .11 for system operation throughout the test period, the following information shall also be provided:
- .1 documentation of all ballast water operations including volumes and locations of uptake and discharge, and if heavy weather was encountered and where;
- .2 documentation that the BWMS was operated continuously throughout the test period for all ballasting and deballasting of the ship;
- .3 documentation detailing water quality parameters identified by the test

- organization that is to be provided as appropriate and practicable;
- .4 the possible reasons for an invalid test cycle, or a test cycle discharge failing the D-2 standard, which is to be investigated and reported to the Administration;
- .5 documentation of scheduled maintenance performed on the system during the test period;
- .6 documentation of unscheduled maintenance and repair performed on the system during the test period;
- .7 documentation of engineering parameters, monitored as appropriate to the specific system; and
- .8 a report detailing the functioning of the control and monitoring equipment.

Land-based testing

2.2.9 The land-based testing provides data to determine the biological efficacy and environmental acceptability of the BWMS under consideration for type approval. The approval testing aims to ensure replicability and comparability to other treatment equipment.

2.2.10 Any limitations imposed by the BWMS on the testing procedure described here are to be duly noted and evaluated by the Administration.

2.2.11 The test set-up including the BWMS is to operate as described in the provided operation, maintenance and safety manual during at least five consecutive successful test cycles in each salinity.

2.2.12 A land-based test cycle is to include the uptake of ballast water by pumping, the storage of ballast water, treatment of ballast water within the BWMS (except in control tanks), and the discharge of ballast water by pumping. The order will be dependent on the BWMS.

2.2.13 At least two test cycles in each salinity tested is to be conducted in order to evaluate compliance with the D-2 standard at the minimum holding time specified by the BWMS manufacturer.

2.2.14 Test facilities carrying out identification of Relevant Chemicals and toxicity testing of the treated ballast water from test cycles with a storage time which is shorter or longer than five days is to ensure that sufficient volumes of treated water are collected after five days or are reserved after the efficacy testing to permit the requirements given in G9 guidelines, for approval of BWMS making use of Active Substances, to be assessed for at least one test cycle per salinity.

2.2.15 Land-based testing of BWMS is to be independent of the system manufacturer.

2.2.16 Testing is to occur using different water conditions sequentially as provided for in paragraphs 2.2.29 and 2.2.31.

2.2.17 The BWMS is to be tested at its TRC or as given in paragraphs 2.25 to 2.28 for each test cycle. The equipment shall function to specifications during this test.

2.2.18 The analysis of treated water discharge from each test cycle is to determine if the treated discharge meets regulation D-2.

2.2.19 The analysis of treated water discharge from the relevant test cycle(s) is to also be used to evaluate the formation of Relevant Chemicals as well as the toxicity of the discharged water for BWMS that make use of Active Substances. The same evaluation shall be conducted for those BWMS that do not make use of Active Substances or preparations but which could reasonably be expected to result in changes to the chemical composition of the treated water such that adverse impacts to receiving waters might occur upon discharge. Toxicity tests of the treated water discharge shall be conducted, taking into account G9 guidelines.

Land-based testing set-up

2.2.20 The test set-up for approval tests is to be representative of the characteristics and arrangements of the types of ships in which the equipment is intended to be installed. The test set-up shall therefore include at least the following:

- .1 the complete BWMS to be tested;
- .2 piping and pumping arrangements; and
- .3 the storage tank that simulates a ballast tank, constructed such that the water in the tank shall be completely shielded from light.

2.2.21 The control and treated simulated ballast tanks is to each include:

- .1 a minimum capacity of 200 m³;
- .2 the use of standard industry practices for design and construction for ships; surface coatings shall be in accordance with the Performance standard for protective coatings of dedicated seawater ballast tanks on all new ships and of double-sided skin spaces of bulk carriers (PSPC) (resolution MSC.215(82)); and
- .3 the minimum modifications required for structural integrity on land.

2.2.22 The control and treated simulated ballast tanks is to include normal internal structures, including lightening and drainage holes.

2.2.23 The test set-up is to be pressure-washed with tap water, dried and swept to remove loose debris,

organisms and other matter before starting testing procedures, and between test cycles.

2.2.24 The test set-up is to include facilities to allow sampling as described in paragraphs 2.2.40 and 2.2.41 and provisions to supply influents to the system, as specified in paragraphs 2.2.29, 2.2.30, 2.2.33 and 2.2.34. The installation arrangements is to conform in each case with those specified and approved under the procedure outlined in section 7 of BWMS Code.

Ballast water management system scaling

2.2.25 Scaling of the BWMS should take into account requirements given in “Guidelines on scaling of BWMS (BWM.2/Circ.33/Rev.1)”. The Administration/RO is to verify that the scaling used is appropriate for the operational design of the BWMS.

2.2.26 BWMS with at least one model with a TRC equal to or smaller than 200 m³/h is not to be downscaled.

2.2.27 For BWMS with at least one model that has a TRC higher than 200 m³/h or 1000 m³/h the following must be observed for land-based testing. In-line treatment equipment may be downsized for land-based testing, but only when the following criteria are taken into account:

- .1 BWMS with at least one model with a TRC higher than 200 m³/h but lower than 1,000 m³/h may be downscaled to a maximum of 1:5 scale, but may not be lower than 200 m³/h; and
- .2 BWMS with at least one model with a TRC equal to, or higher than, 1,000 m³/h may be downscaled to a maximum of 1:100 scale, but may not be lower than 200 m³/h.

2.2.28 In-tank treatment equipment is to be tested on a scale that allows verification of full-scale effectiveness. The suitability of the test set-up is to be evaluated by the manufacturer and approved by the Administration/RO.

Land-based test design – inlet and outlet criteria

2.2.29 For any given set of test cycles (five are considered a set) a salinity range is to be chosen for each cycle. Given the salinity of the test set-up for a test cycle in fresh, brackish and marine water, each is to have dissolved and particulate content in one of the combinations set out in the table below. Deviations from the marine and brackish salinity ranges of the table is to be reported and justified and the resulting tests are not to be less challenging for the BWMS than would be the circumstance if the deviations had not occurred:

	Salinity		
	Marine 28 – 36 PSU	Brackish 10 – 20 PSU	Fresh < 1 PSU
Dissolved Organic Carbon (DOC)	> 1 mg/L	> 5 mg/L	> 5 mg/L
Particulate Organic Carbon (POC)	> 1 mg/L	> 5 mg/L	> 5 mg/L
Total Suspended Solids (TSS)	> 1 mg/L	> 50 mg/L	> 50 mg/L

2.2.30 The source of the test water is to be natural water. Any augmentation of test water with dissolved organic carbon (DOC), particulate organic carbon (POC) or total suspended solids (TSS) to achieve the minimum required content is to be validated and approved by the Administration. As natural DOC constituents are complex and primarily of aromatic character, the type of added DOC is particularly critical to the evaluation of BWMS performance. The validation is to ensure that relevant properties of the augmented water (such as the oxidant demand/TRO decay and UV absorption in the range of 200 to 280 nm, the production of disinfectant by-products and the particle size distribution of suspended solids) are equivalent, on a mg/L basis, to that of natural water that would quantitatively meet the challenge conditions. In addition, the validation is to ensure that augmentation does not bias a test for or against any specific treatment process. The test report shall include the basis for the selection, use and validation of augmentation.

2.2.31 The BWMS must be tested in conditions for which it will be approved. For a BWMS to achieve an unlimited Type Approval Certificate with respect to salinity, one set of test cycles is to be conducted within each of the three salinity ranges with the associated dissolved and particulate content as prescribed in paragraph 2.2.29 above. Tests under adjacent salinity ranges in the above table is to be separated by at least 10 PSU.

2.2.32 Use of standard test organisms (STO):

- .1 the use of standard test organisms (STO) is permissible if the challenge levels in naturally occurring water at the test facility require supplementation. The use of STO is not to be considered standard practice and the Administration shall in every case review that the selection, number and use of supplementary STOs ensures that the challenge posed to the BWMS provides an adequately robust test. The use of STOs is not to bias a test for or

against any specific treatment process. They are to be locally isolated to ensure that the risk to the local environment is minimized; non-indigenous organisms which have the potential to cause harm to the environment shall not be used;

.2 procedures, processes and guidance for the use of STO are to be based on the most relevant and up-to-date available scientific data. Such procedures, processes and guidance are to form a part of the testing facilities quality assurance regimes; and

.3 the use of STO, including concentrations and species, are to be recorded within the test report. The test report is to include information pertaining to the evaluation and justification for the use of STO, an assessment of the impact of their use on other test parameters and potential impacts on the test being undertaken. The information contained within the report is to reflect both the positive and negative impacts of the use of STO.

2.2.33 The influent water shall include:

.1 test organisms of greater than or equal to 50 µm or more in minimum dimension that are to be present in a total density of preferably 10⁶ but not less than 10⁵ individuals per cubic metre, and is to consist of at least five species from at least three different phyla/divisions;

.2 test organisms greater than or equal to 10 µm and less than 50 µm in minimum dimension that are to be present in a total density of preferably 10⁴ but not less than 10³ individuals per mL, and are to consist of at least five species from at least three different phyla/divisions;

.3 heterotrophic bacteria that are to be present in a density of at least 10⁴ living bacteria per mL; and

.4 a variety of organisms which shall be documented according to the size classes mentioned above regardless of whether natural organism assemblages or cultured organisms were used to meet the density and organism variety requirements.

2.2.34 The following bacteria do not need to be added to the influent water, but are to be measured at the influent and at the time of discharge:

.1 coliform;

.2 Enterococcus group;

.3 *Vibrio cholerae*; and

.4 heterotrophic bacteria.

2.2.35 If cultured test organisms are used, local applicable quarantine regulations are to be taken into account during culturing and discharge.

Land-based monitoring and sampling

2.2.36 Change of numbers of test organisms by treatment and during storage in the simulated ballast tank are to be measured using methods described in Para 2.4 of this guidelines (paragraphs 2.4.5 to 2.4.7).

2.2.37 It shall be verified that the treatment equipment performs within its specified parameters, such as power consumption and flow rate, during the test cycle.

2.2.38 The range of operational flow rates that a BWMS is expected to achieve in service, at the maximum and minimum operational flow rates (where it is appropriate for that technology), shall be verified after the filter on the discharge side of the pump. The range of flow rate may be derived from empirical testing or from computational modelling. Where appropriate for the technology, demonstration of system efficacy at low flow rates is to reflect the need for flow reduction during the final stages of ballast operations.

2.2.39 Environmental parameters such as pH, temperature, salinity, dissolved oxygen, TSS, DOC, POC and turbidity (Nominal Turbidity Unit, NTU) are to be measured at the same time that the samples described are taken.

2.2.40 Samples during the test for the purposes of determining biological efficacy is to be taken at the following times and locations: immediately before the treatment equipment, immediately after the treatment equipment and upon discharge after the appropriate holding time.

2.2.41 The control and treatment cycles may be run simultaneously or sequentially. Control samples are to be taken in the same manner as the equipment test as prescribed in paragraph 2.40 above and upon influent and discharge.

2.2.42 Facilities or arrangements for sampling are to be provided to ensure representative samples of treated and control water can be taken that introduce as little adverse effects as possible on the organisms.

2.2.43 Samples described in paragraphs 2.40 and 2.41 above are to be collected with the following sampling regime and volumes for analysis:

.1 for the enumeration of viable organisms greater than or equal to 50 µm or more in minimum dimension:

.1 influent water is to be collected over the duration of uptake as one time-integrated sample. The sample shall be collected as a single, continuous sample or a composite of sequential samples, e.g. collected at intervals during the beginning, middle and end of the operation. The total sample volume is to be at least one cubic metre. If smaller volume is validated to ensure representative sampling of

organisms, it may be used;

.2 control and treated discharged water are to be collected as one time-integrated sample over the duration of discharge from the tank(s). The sample may be collected as a single, continuous sample or a composite of sequential samples, e.g. collected throughout the beginning, middle and end the operation. The total sample volume is to be at least 3 m³;

.3 if samples are concentrated for enumeration, the organisms are to be concentrated using a mesh with holes no greater than 50 µm in the diagonal dimension. Only organisms greater than 50 µm in minimum dimension shall be enumerated; and

.4 the full volume of the sample is to be analyzed unless the total number of organisms is high, e.g. 100. In this case, the average density may be extrapolated based on a well-mixed subsample using a validated method;

.2 for the enumeration of viable organisms greater than or equal to 10 µm and less than 50 µm in minimum dimension:

.1 influent water is to be collected over the duration of uptake as one, time-integrated sample. The sample is to be collected as a single, continuous sample or a composite of sequential samples, e.g. collected at intervals during the beginning, middle and end of the operation. A sample of at least 10 L is to be collected, and a fraction may be subsampled for transport to the laboratory, provided it is representative of the sample and is a minimum of 1 L. A minimum of three 1 mL subsamples shall be analyzed in full to enumerate organisms;

.2 control and treated discharged water are to be collected as one time-integrated sample over the duration of discharge from the tank(s). The sample may be collected as a single, continuous sample or a composite of sequential samples, e.g. collected throughout the beginning, middle and end the operation. A sample of at least 10 L shall be collected, and a fraction may be subsampled for transport to the laboratory, provided it is representative of the sample and is a minimum of 1 L. A minimum of six 1 mL subsamples are to be analyzed in full to enumerate organisms;

.3 the sample may not be concentrated for analysis unless the procedure is validated. Only organisms greater than 10 µm and less than 50 µm in minimum dimension is to be enumerated; and

.4 the full volume of the sample is to be analysed unless the total number of organisms is high, e.g. 100. In this case, the average density may be extrapolated based on a well-mixed subsample using a validated method; and

.3 for the evaluation of bacteria:

.1 for the influent and discharge samples, a minimum 10 L sample referred to in paragraphs 2.2.8.6.2.1 and 2.2.8.6.2.2 above, respectively, or another sample at least 10 L in volume and collected in a similar manner, are to be used; a subsample of minimum 1 L may be transferred to a sterile container for analysis;

.2 a minimum of three subsamples of appropriate volume taken from the 1 L subsample described above is to be analyzed for colony forming units of bacteria listed in regulation D-2; and

.3 the toxicogenic test requirements shall be conducted in an appropriately approved laboratory. If no approved laboratory is available, the analysis method may be validated to the satisfaction of the Administration.

2.2.44 The samples shall be analyzed as soon as possible after sampling and analyzed live within six hours or treated in such a way so as to ensure that proper analysis can be performed.

2.2.45 If in any test cycle the discharge results from the control water is of a concentration less than or equal to 10 times the values in regulation D-2.1, the test cycle is invalid.

Temperature

2.2.46 The effective performance of BWMS through a ballast water temperature range of 0°C to 40°C (2°C to 40°C for fresh water) and a mid-range temperature of 10°C to 20°C is to be the subject of an assessment verified by the Administration.

2.2.47 This assessment may include:

.1 testing during land-based, shipboard, laboratory or bench-scale testing; and/or

.2 the use of existing data and/or models, provided that their source, suitability and reliability is reported.

2.2.48 The report submitted to the Administration is to contain all documentation (including procedures, methods, data, models, results, explanations and remarks) associated with the temperature assessment. The report is to include at least the information identified in paragraph 2.57 of this annex.

Evaluation of regrowth

2.2.49 The evaluation of the regrowth of organisms is to be undertaken to the satisfaction of the Administration in land-based and/or shipboard testing in at least two test cycles in each salinity.

2.2.50 In the case of land-based testing being performed with a holding time of less than five days, a sufficient volume of treated uptake water shall be held under conditions similar to conditions in the relevant holding tank. In the case of shipboard testing, water is to be retained on board for the evaluation of regrowth during a shipboard test cycle. Additional bench-scale testing may be used to supplement the land-based and/or shipboard testing.

2.2.51 In the case of a BWMS that includes mechanical, physical, chemical and/or biological processes intended to kill, render harmless or remove organisms within ballast water at the time of discharge or continuously between the time of uptake and discharge, regrowth shall be assessed in accordance with sections "Shipboard tests" and "Land-based testing" of this annex with a holding time of at least five days.

2.2.52 Otherwise, the enumeration of organisms to assess regrowth is to be undertaken at least five days after the completion of all of the mechanical, physical, chemical and/or biological processes intended to kill, render harmless or remove organisms within ballast water.

2.2.53 Any neutralization of ballast water required by the BWMS shall occur at the end of the holding time and immediately before the enumeration of organisms.

2.2.54 The evaluation of regrowth is not intended to evaluate contamination in ballast tanks or piping, such as may arise from the presence of untreated water or residual sediments.

2.2.55 A report is to be submitted to the Administration containing all documentation (including procedures, methods, data, models, results, explanations and remarks) associated with the evaluation of regrowth. The report is to include at least the information identified in paragraph 2.57 of this annex.

Reporting of test results

2.2.56 After approval tests have been completed, a report is to be submitted to the Administration. This report is to include information regarding the test design, methods of analysis and the results of these analyses for each test cycle (including invalid test cycles), BWMS maintenance logs and any observed effects of the BWMS on the ballast system of the ship (e.g. pumps, pipes, tanks, valves). Shipboard test reports are to include information on the total and continuous operating time of the BWMS.

2.2.57 The reports submitted in accordance with paragraph 2.2.56 above is to contain at least the following information:

- .1 the name and address of the laboratory performing or supervising the inspections, tests or evaluations, and its national accreditation or quality management certification, if appropriate;
- .2 the name of the manufacturer;
- .3 the trade name, product designation (such as model numbers), and a detailed description of the equipment or material inspected, tested or evaluated;
- .4 the time, date, and place of each approval inspection, test or evaluation;
- .5 the name and title of each person performing, supervising, and witnessing the tests and evaluations;
- .6 executive summary;
- .7 introduction and background;
- .8 for each test cycle, inspection or evaluation conducted, summary descriptions of:
 - .1 experimental design;
 - .2 methods and procedures;
 - .3 results and discussion, including a description of any invalid test cycle (in the case of a report referred to in part 2 of this annex) and a comparison to the expected performance; and
 - .4 in the case of land-based testing, test conditions including details on challenge water preparation in line with paragraph 2.30 of this annex;
- .9 a description or photographs of the procedures and apparatus used in the inspections, tests or evaluation, or a reference to another document that contains an appropriate description or photographs;
- .10 at least one photograph that shows an overall view of the equipment or material tested, inspected or evaluated and other photographs that show:
 - .1 design details; and
 - .2 each occurrence of damage or deformation to the equipment or material that occurred during the approval tests or evaluations;
- .11 the operational safety requirements of the BWMS and all safety-related findings that have been made during the inspections, tests or evaluations;
- .12 an attestation that the inspections, tests or evaluations were conducted as required and that the report contains no known errors, omissions or false statements. The attestation must

be signed by:

- [.1 the manufacturer or manufacturer's representative, if the inspection, tests or evaluations are conducted by the manufacturer; or]
- .2 the chief officer of the laboratory, or the chief officer's representative, if the inspection or tests were conducted by an independent laboratory;
- .13 appendices, including:
 - .1 the complete test plan and the data generated during tests and evaluations reported under paragraph 2.57.8 above, including at least:
 - .1 for land-based tests, whether ambient, cultured or a mixture of test organisms have been used (including a species-level identification for cultured organisms, and an identification to the lowest possible taxonomic level for ambient organisms);
 - .2 for shipboard tests, the operating parameters of the system during successful treatment operations (e.g. dosage rates, ultraviolet intensity and the energy consumption of the BWMS under normal or tested TRC, if available);
 - .3 for SDL, details of all procedures, methods, data, models, results, explanations and remarks, leading to validation; and
 - .4 invalid test information.
 - .2 the QMP, the QAPP and Quality Assurance and Quality Control records;
 - .3 maintenance logs including a record of any consumable components that were replaced; and
 - .4 relevant records and test results maintained or created during testing.

2.2.58 The results of biological efficacy testing of the BWMS is to be accepted if during the land-based and shipboard testing conducted as specified in sections "Shipboard tests" and "Land-based testing" of this annex it is shown that the system has met the standard in regulation D-2 and that the uptake water quality requirements were met in all individual test cycles as provided in paragraph 2.4.7 below.

2.2.59 The test report is to include all test cycles during land-based and shipboard tests, including failed test cycles and invalid test cycles with the explanation required in paragraph 2.2.8.11.4 for both shipboard and land-based tests.

2.2.60 The Administration shall identify and redact commercially sensitive information (information that is proprietary and not related to the BWMS performance) and make all other information available to interested parties and the Organization. The information is to include all of the test reports, including failed tests from both land-based and shipboard testing.

2.3 Specification for environmental testing for approval of BWMS

2.3.1 The electrical and electronic sections of the BWMS in the standard production configuration are to be subject to the relevant tests specified in paragraph 2.3.3 below at a laboratory approved for the purpose by the Administration/RO or by the accreditation body of the laboratory, with relevant accreditation (as per ISO/IEC 17025:2017) covering the relevant test standards.

2.3.2 Evidence of successful compliance with the environmental tests below is to be submitted to the Administration/RO by the manufacturer together with the application for type approval.

2.3.3 Equipment is to be tested taking into account IACS UR E10, Rev.6.

2.3.4 A report on environmental tests is to be submitted to the Administration/RO and include at least the information identified in paragraph 2.2.57 of this Annex.

2.4 Reporting

2.4.1 Introduction

2.4.1.1 BWMS is to monitor and store a minimum number of parameters for detailed evaluation. In addition, all system indications and alerts are to be stored and available for inspection. Data storage and retrieval are to follow common standards. This part gives an overview of the minimum required self-monitoring parameters.

2.4.2 Monitoring of parameters

2.4.2.1 The applicable self-monitoring parameters listed below are to be recorded for every BWMS. Any additional parameters that are necessary to ascertain system performance and safety are to be determined by the Administration and stored in the system. If a parameter is not applicable due to the particulars of the system, the Administration/RO may waive the requirement to record that parameter. Limiting operating conditions on the operation of the BWMS are to be determined by the manufacturer and approved by the Administration/RO.

2.4.3 General information for all systems

2.4.3.1 The information and applicable self-monitoring parameters to be recorded for all systems are to include, inter alia:

- .1 general information: ship name, IMO number, BWMS manufacturer and type designation, BWMS serial number, date of BWMS installation on ship, BWMS TRC and principle of treatment (in-line/in-tank);
- .2 operational parameters: all recorded parameters are to be time tagged if applicable: BWMS operational modes and any transition modes, including bypass operations (e.g. uptake, discharge, warming-up, cleaning and start up), ballast water pump in operation (yes/no – if information is available from ship), flow-rate at system outlet, and indication of the ballast water tank that is involved in the ballast water operation when practicable;
- .3 it is recommended that positional information on ballast water operations and on the holding time are to be recorded automatically. Otherwise it is to be entered manually in the Ballast Water Record Book as appropriate. Administrations are encouraged to apply automatic position information recording to ships which install BWMS during a ship's building to the greatest extent possible;
- .4 system alerts and indications: all systems are to have an alert regime. Every alert is to be logged and time stamped. To assist the inspection, it would be helpful to record an alert summary after each ballast water operation automatically, if possible;
- .5 general alerts include: shutdown of system while in operation, when maintenance is required, BWMS bypass valve status and status of BWMS valves representing system operational mode as appropriate;
- .6 operational alerts: whenever a relevant parameter exceeds the acceptable range approved by the Administration, the system is to give an alert. In addition, an alert is to be logged and time stamped also when a combination of relevant parameters exceeds system specifications, even if each single parameter does not exceed its approved range. If a safety relevant parameter (safety for crew, cargo and/or the ship) related to the BWMS exceeds approved limits, an alert/alarm is to be mandatory (e.g. hydrogen level at appropriate measurement point(s));
- .7 the Administration/RO may require additional alerts depending on the design of the system and for future developments; and
- .8 the SDL parameters and their corresponding data such as range, alarm limit, alert delay etc. be password protected on a level above what is required for normal operation and maintenance, i.e. on a system administrator level. Change of any data or parameters which are password protected and interruption of the measurement (wire break, signal out of range) is to be automatically logged and retrievable on a maintenance access level.

2.4.4 Data storage and retrieval

2.4.4.1 Storage of data is to follow the requirements in "Control and Monitoring equipment" of BWMS Code (refer paragraphs 4.17 to 4.22 of the Code). The equipment is to be able to store a minimum number of self-monitoring parameters following common standards determined by the Organization.

2.4.4.2 The control and monitoring equipment is to automatically record the proper functioning or failure of a BWMS without user interaction and add a time stamp to every entry. Additionally, the system is to have a tool to produce summary text files for each ballast water operation on demand to support inspections work.

2.4.4.3 The system is to store the required data in an acceptable format to be able to display, print or export the data for official inspections. An acceptable format could be:

- .1 an internationally standardized readable format (e.g. text format, pdf, MS Excel); or
- .2 the extensible mark-up language (xml).

2.4.4.4 The equipment is to be so designed that, as far as is practical, it will not be possible to manipulate either the data being stored by the system or the data which has already been recorded. Any attempt to interfere with the integrity of the data is to be recorded.

2.4.4.5 Permanent deletion of recordings are not to be possible. The system is to be capable of storing recorded data for at least 24 months to facilitate compliance with regulation B-2 of the Convention. Where navigation equipment is connected to the monitoring system to provide data for recording, the interfaces are to be developed taking into account applicable parts of relevant international standards (Refer to Digital interfaces for navigational equipment within a ship (IEC 61162)).

2.5 Validation of System Design Limitations

2.5.1 The objective of the SDL approach is twofold. Firstly, it ensures that the performance of the BWMS has been transparently assessed with respect to the known water quality and operational parameters that are important to its operation, including those that may not be specifically provided for in this Code. Secondly, it provides transparent oversight of BWMS performance claims by the manufacturer that may go beyond specific criteria in this Code. Although the validation of SDL yields information that is reported on the Type Approval Certificate, this information does not affect the eligibility of a BWMS to receive type

approval.

2.5.2 The low and/or high parameter values for each SDL are to be validated to the satisfaction of the Administration as follows:

- .1 the validation is to be overseen by the Administration/RO and is to consist of a rigorous evidence-based assessment of a specific claim by the BWMS manufacturer that the equipment will operate as intended between pre-stated parameter values;
- .2 tests to validate SDL is to be undertaken in accordance with paragraphs 2.2 to 2.4 of this annex. Such tests may be combined with land-based and/or shipboard testing if the QAPP establishes that the validation tests will not interfere with the specific procedures in part 2 of this annex. Laboratory or bench-scale testing may also be used in the validation of SDL;
- .3 methods other than testing, such as the use of existing data and/or models, may be used in the validation of SDL. The source, suitability and reliability of such methods shall be reported; and
- .4 validation is not intended as a stress-test of the BWMS or as a procedure for identifying equipment failure points. Validation is to be undertaken independently of the BWMS manufacturer and is to be separate from BWMS research and development activities. Data and models may be supplied by the manufacturer when appropriate but is to be independently assessed.

2.5.3 Claims of open-ended performance (expressed as the lack of either a low or a high parameter value for a System Design Limitation) shall also be validated.

2.5.4 BWMS manufacturers may include a margin of error in claiming SDL. For this reason, SDL is not necessarily to be interpreted as the exact parameter values beyond which the BWMS is incapable of operation. The Administration/RO is to take this into account in considering whether to include any additional restrictions on the Type Approval Certificate in connection with the validation of SDL.

2.5.5 SDL is to be established for all known parameters to which the design of the BWMS is sensitive that are important to the operation of the BWMS. In the case of SDL parameters that are also subject to specific criteria in Para 2.2 above, the procedure set out in Para 2.2 above is to be followed. For such parameters, the approach in paragraph 2.5.2 above may be used only to the extent that the performance claim goes beyond the specific criteria in Para 2.2.

2.6 Reporting of test results

- After approval tests have been completed, a report should be submitted to the Administration /RO. This report should include information regarding the test design, methods of analysis and the results of these analyses.
- The report is to also contain all documentation (including procedures, methods, data, models, results, explanations and remarks) associated with the validation of SDL. The report is to include at least the information identified in paragraph 2.2.57 above.
- The results of biological efficacy testing of the BWMS should be accepted if during the land-based and shipboard testing conducted as specified in sections 2.2.2 and 2.2.3, it is shown that the system has met the standard in regulation D-2 in all test cycles as provided in paragraph 2.2.4.2 above.

2.7 Issue of Type Approval Certificate

On successful verification of the results of all the above tests, Type Approval Certificate is issued. Format of the certificate can be viewed in Ch 4, paragraph 4.2 Appendix A.

3 PROCEDURE FOR EVALUATION OF BWMS SYSTEM - Type Approval of ballast water management systems using Active Substances

3.1 Basic Approval

3.1.1 Introduction

3.1.1.1 This procedure describes the approval and withdrawal of approval of Ballast Water Management systems that make use of Active Substances to comply with the Convention and their manner of application as set out in Regulation D-3 of the "International Convention for the Control and Management of Ships' Ballast Water and Sediments". The Convention requires that at withdrawal of approval, the use of the relevant Active Substance or Substances shall be prohibited within 1 year after the date of such withdrawal. Ballast Water Management systems that make use of Active Substances or Preparations containing one or more Active Substances shall be approved by the Organization, based on a procedure developed by the Organization. The objective of this procedure is to determine the acceptability of Active Substances and Preparations containing one or more Active Substances and their application in Ballast Water Management systems concerning ship safety, human health and the aquatic environment. This procedure is provided as a safeguard for the sustainable use of Active Substances and Preparations.

3.1.2 Principles

- Active Substances and Preparations may be added to the ballast water or be generated on board ships by technology within the Ballast Water Management system using an Active Substance to comply with the Convention.
- Active Substances and Preparations accomplish their intended purpose through action on Harmful Aquatic Organisms and Pathogens in ships' ballast water and sediments. However, if the ballast water is still toxic at the time of discharge into the environment, the organisms in the receiving water may suffer unacceptable harm. Both the Active Substance and Preparation as well as the Ballast Water Discharge should be subjected to toxicity testing in order to protect the receiving environment or human health from toxic effects due to the discharges. Toxicity testing is needed to determine if an Active Substance or Preparation can be used and under which conditions the potential of harming the receiving environment or human health is acceptably low.
- Any system which makes use of, or generates, Active Substances, Relevant Chemicals or free radicals during the treatment process to eliminate organisms in order to comply with the Convention should be subject to this Procedure.
- Ballast water management systems that make use of Active Substances and Preparations must be safe in terms of the ship, its equipment and the personnel to comply with the Convention.
- The approval of Active Substances and Preparations using viruses or fungi for use in ballast water management systems is not addressed in this procedure. The approval of such substances for ballast water management should require an additional consideration by the Organization in compliance with regulation D-3 of the Convention if the use of such substances is proposed.
- Administrations/RO will check the quality and completeness of any Basic Approval or Final Approval submission, against the latest version of the Methodology for information gathering and the conduct work of the Technical Group agreed by the Organization, prior to its submission to the MEPC.

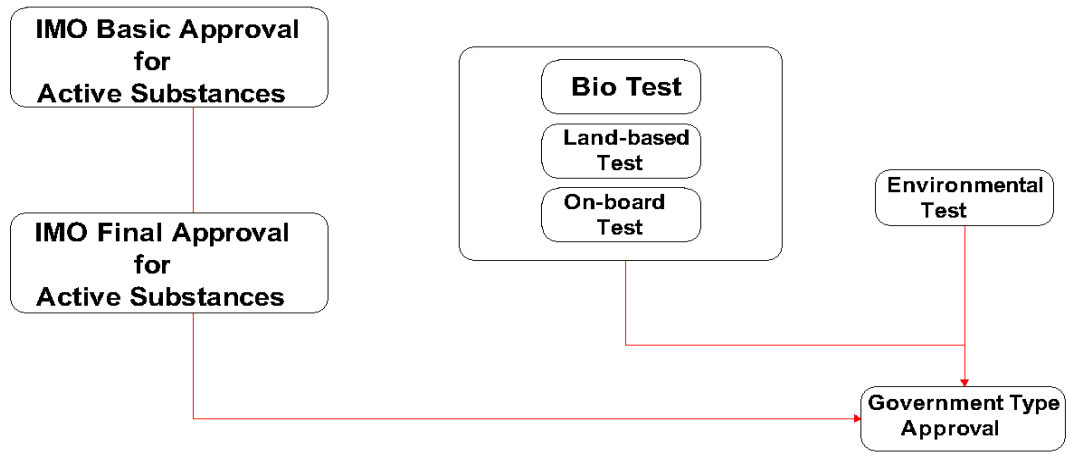

The manufacturer should evaluate the Active Substances or Preparations and the potential discharge in accordance with the approval criteria specified in the procedure. Upon completion, the manufacturer should prepare an Application on the Active substances and Preparations and submit it to the Member of the Organization concerned. An application should only be made once the ballast water management system, Active Substance or Preparation has been sufficiently designed, progressed and tested to provide the full data necessary for a Basic Approval. The Administration having received a satisfactory application will as soon as possible propose an approval to the Organization. Active Substances or Preparations receiving basic approval by the Organization may be used for prototype or type approval testing based on the guidelines developed by the Organization. A written agreement is to be provided by the applicant whose Active Substance or Preparation has been granted the initial Basic Approval. The process flow diagram for Basic Approval is shown below.

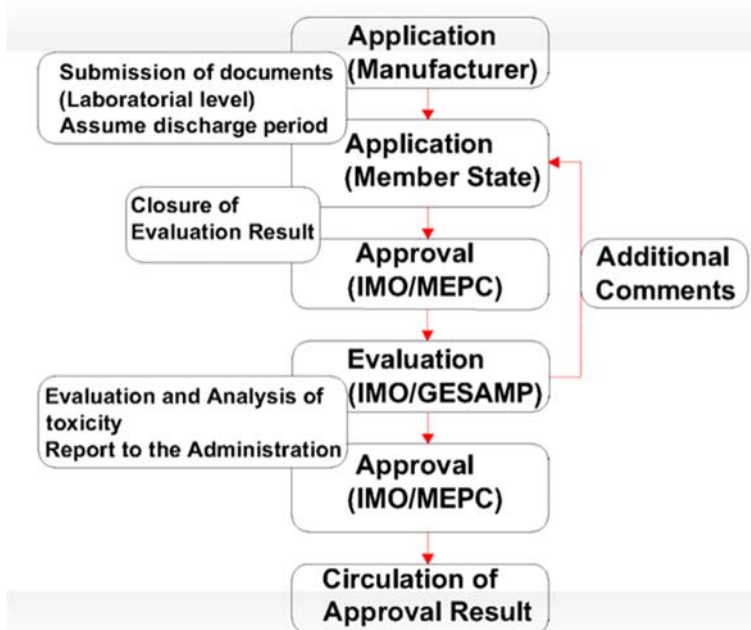

3.1.3 General requirements

Identification

- The proposal for approval of an Active Substance or a Preparation should include a chemical identification and description of the chemical components even if generated onboard. A chemical identification should be provided for any Relevant Chemicals.
- Data-set for Active Substances and Preparations
- A proposal for approval should include information on the properties or actions of the Preparation including any of its components as follows:
 - .1 Data on effects on aquatic plants, invertebrates, fish, and other biota, including sensitive and representative organisms:
 - Acute aquatic toxicity;
 - Chronic aquatic toxicity;
 - Endocrine disruption;
 - Sediment toxicity;
 - Bioavailability/Biomagnifications/Bioconcentration; and
 - Food web/Population effects.
 - .2 Data on mammalian toxicity:
 - Acute toxicity;
 - Effects on skin and eye;
 - Chronic and long-term toxicity;

-
- Developmental and reproductive toxicity;
 - Carcinogenicity; and
 - Mutagenicity
- .3 Data on environmental fate and effect under aerobic and anaerobic conditions:
- Modes of degradation (biotic; abiotic);
 - Bioaccumulation, partition coefficient, octanol/water coefficient;
 - Persistence and identification of the main metabolites in the relevant media (ballast water, marine and fresh waters);
 - Reaction with organic matter;
 - Potential physical effects on wildlife & benthic habitats;
 - Potential residues in seafood; and
 - Any known interactive effects.
- .4 Physical and chemical properties for the Active Substances and Preparations and the treated ballast water, if applicable:
- Melting point;
 - Boiling point;
 - Flammability;
 - Density (relative density);
 - Vapour pressure, Vapour density;
 - Water solubility / Dissociation constant (pKa);
 - Oxidation/reduction potential;
 - Corrosivity to the materials or equipment of normal ship construction;
 - Autoignition temperature; and
 - Other known relevant physical or chemical hazards.
- .5 Analytical methods at environmentally relevant concentrations.
- A proposal for approval should include the above data set either for the Preparation or for each component separately, and a list of the name and relative quantities (in volumetric percentages) of the components should be also attached. All proprietary data should be treated as confidential.
 - The tests for Active Substances and Preparations should be carried out in accordance with internationally recognized guidelines.
 - The testing process should contain a rigorous quality control/quality assurance programme consisting of:
 - .1 Both a Quality Management Plan (QMP) and a Quality Assurance Project Plan (QAPP). Guidance on preparation of these plans, along with other guidance documents and other general quality control information are available for download from the International Organization for Standardization (ISO) (www.iso.org)
 - .2 The QMP addresses the quality control management structure and policies of the Test Organization (Including subcontractors and outside laboratories).
 - .3 The QAPP is a project specific technical document reflecting the specifics of the system to be tested, the test facility, and other conditions affecting the actual design and implementation of the required experiments.
 - Dossiers already used for registration of chemicals can be submitted by the applicant to satisfy the required data needed for the evaluation of Active Substances and Preparations according to this procedure.
 - The proposal should describe the manner of application of the Preparation for Ballast Water Management, including required dosage and retention time.
 - A proposal for approval should include Material Safety Data Sheets (MSDS).
 - Assessment report
 - A proposal for approval should include an assessment report. The assessment report should address the quality of the test reports, the risk characterization and a consideration of the uncertainty associated with the assessment.

3.1.4 Risk characterization

Additional tests and requirements in accordance with Procedure for Approval of BWMS that
make use of Active Substances

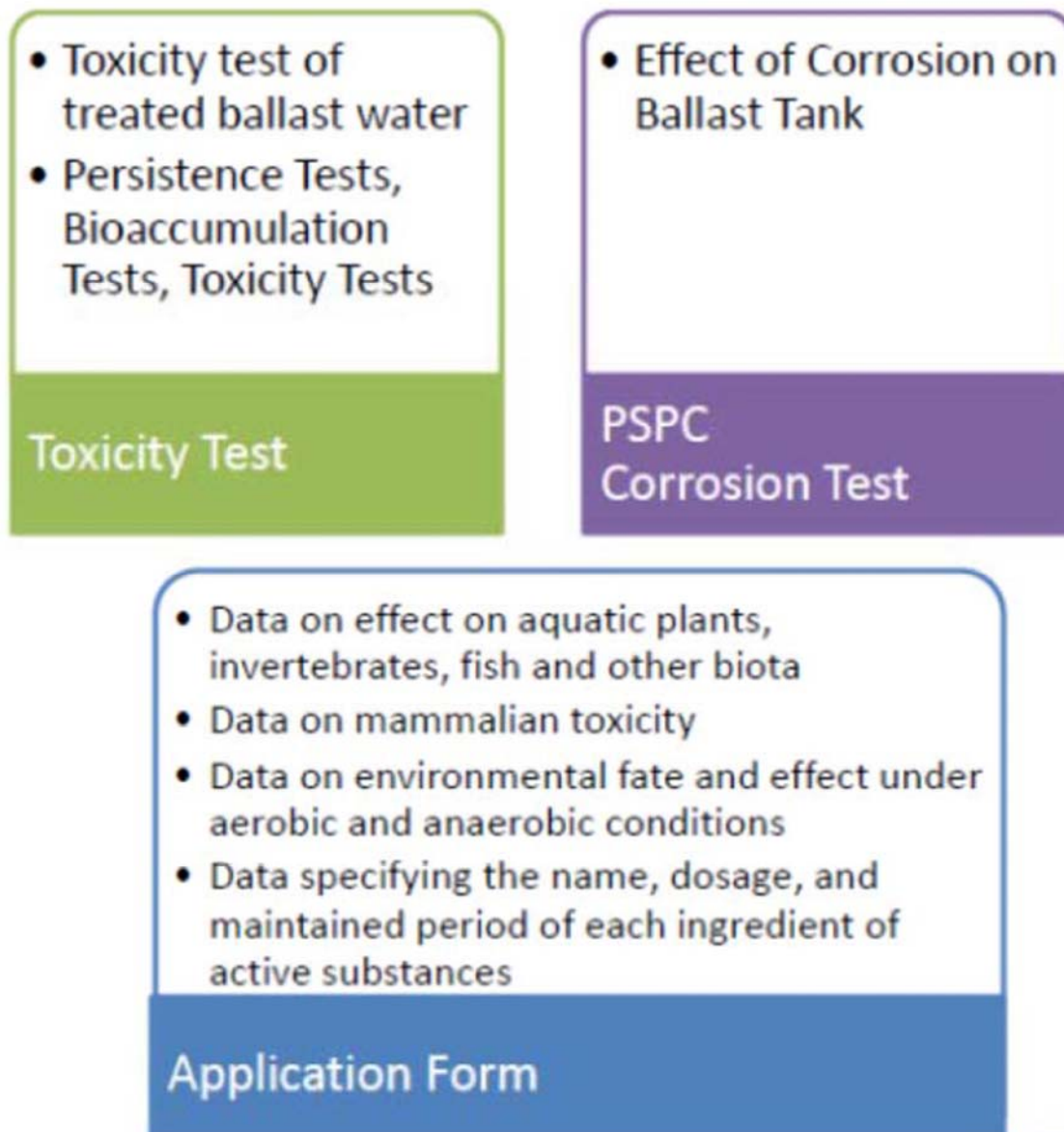

3.1.4.1 Screening for persistency, bioaccumulation and toxicity

- An assessment on the intrinsic properties of the Active Substance and/or Preparation such as persistency, bioaccumulation and toxicity should be conducted (See Table 2).
- .1 Persistence tests: Persistence should preferably be assessed in simulation test systems that determine the half-life under relevant conditions. Biodegradation screening tests may be used to show that the substances are readily biodegradable. The determination of the half-life should include assessment of relevant chemicals.
- .2 Bioaccumulation tests: The assessment of the (potential for) bioaccumulation should use measured bioconcentration factors in marine (or freshwater) organisms. Where these tests are not applicable, or if $\log P_{ow} < 3$, Bio Concentration Factor (BCF) values may be estimated using Quantitative Structure-Activity Relationship (QSAR) models.
- .3 Toxicity tests: Acute and/or chronic ecotoxicity data, ideally covering the sensitive life stages, should in principle be used for the assessment of the toxicity criterion.

3.1.4.2 Toxicity testing of the treated Ballast Water

- Toxicity testing is necessary for the Active Substance or Preparations (See Paragraphs 3.1.3 and 3.1.4.3) and the treated Ballast Water Discharge as covered in this section. The advantage of conducting toxicity testing on the Ballast Water Discharge is that it integrates and addresses the potential for interactions of the Active Substances and Preparations with the possible by-products.
- .1 For the basic approval process, the discharge testing should be performed in a laboratory using techniques and equipment to simulate Ballast Water Discharge following treatment by the Preparation.
- .2 For final approval, the discharge testing should be performed as part of the land-based type approval process using the treated ballast water discharge.
- The applicant should provide both acute and chronic toxicity test data using standardized test procedures to determine the toxicity of the Preparation and Relevant Chemicals as used in conjunction with the Ballast Water Management System. This testing approach should be performed on the treated Ballast Water Discharge, as the Ballast Water Management system could either mitigate or enhance the adverse effects of the Preparation or Relevant Chemicals.
- The discharge toxicity tests should be conducted on samples drawn from the land-based test set-up, which would be representative of the discharge from the Ballast Water Management system.
- These toxicity tests should include chronic test methods with multiple test species (A fish, an invertebrate and a plant) that address the sensitive life-stage. The preference is to include both a sub-lethal endpoint (Growth) and a survival endpoint. Either freshwater or marine test methods should be tested*.

*If there is physiological or empirical proof those marine organisms are more sensitive than freshwater organisms or vice versa, this should be taken into account.

- The test results to be provided include: acute 24-hour, 48-hour, 72-hour, and 96-hour Lethal Concentration at which x % of the test organisms die (LCx), No Observed Adverse Effect Concentrations (NOAECs), chronic No Observed Effect Concentration (NOEC) and/or Effect Concentration at which x % of test organisms show effect (ECx), as appropriate based on the experimental design.
- A dilution series including a 100% ballast water discharge would be tested to determine the no adverse effect level using the statistical endpoints (NOEC or ECx). An initial analysis could use a conservative approach where the dilution capacity would not be taken into consideration (no modelling or plumes analysis would be used). The rationale for taking a conservative approach is that there could be multiple discharges into one location (even though this is not necessarily the case).
- The acute and chronic toxicity test data in conjunction with the information in Paragraph 2.2.3 should be used to determine the holding time necessary to achieve the no adverse effect concentration upon discharge. Knowing the half-life (days), decay rate, dosage rate, volume of system and toxicity tests with time series, then a computational model can be used to determine the amount of time needed to hold the treated ballast water before discharge.
- Information on Total Residual Oxidants (TRO) and Total Residual Chlorine (TRC) should be provided as part of the application for evaluation, for both the ballast water treatment process and the ballast water discharge.

3.1.4.3 Risk characterization and analysis

- For the basic approval process, fate and effect testing should be performed in the laboratory with Active Substances and Preparations.
- Active Substance or Preparation as well as the treated Ballast Water Discharge should be subject to toxicity testing in order to protect the receiving environment from toxic effects due to discharges.
- The reaction with organic matter of Active Substances and Preparations that produce free radicals should be addressed qualitatively so as to identify products of concern to the environment.
- The rate and route of abiotic and biotic degradation of the Active Substances and Preparations under aerobic and anaerobic conditions should be assessed,

resulting in the identification of relevant metabolites in the relevant media (ballast water, marine and fresh waters).

- The rate of abiotic and biotic degradation of the Active Substances and Preparations under aerobic and anaerobic conditions should be assessed, resulting in the characterization of the persistence of the Active Substances, Preparations and Relevant Chemicals in terms of degradation rates under specified conditions (e.g. pH, redox, temperature).
- The partition coefficients (solids-water partition coefficient (Kd) and/or organic carbon normalized distribution coefficient (Koc)) of the Active Substances, Preparations and Relevant Chemicals should be determined.
- For Active Substances and Preparations, the potential for bioaccumulation should be assessed in marine or freshwater organisms (fish or bivalves) if the logarithm octanol/water partition coefficient (logPow) is >3.
- Based on the information on fate and behavior of Active Substances and Preparations, the discharge concentrations at selected time intervals should be predicted.
- The effect assessment of the Active Substances, Preparations and Relevant Chemicals is initially based on a dataset of acute and/or chronic ecotoxicity data for aquatic organisms, being primary producers (algae or sea grasses), consumers (crustaceans), predators (fish), and should include secondary poisoning to mammalian and avian top-predators, as well as data for sediment species.
- An assessment of secondary poisoning is redundant if the substance of concern demonstrates a lack of bioaccumulation potential (e.g., BCF <500 L/kg wet weight for the whole organism at 6% fat).
- An assessment of sediment species is redundant if the potential of the substance of concern to partition into the sediment is low (e.g., Koc <500 L/kg).
- The effect assessment of the Active Substances, Preparations and Relevant Chemicals should include a screening on carcinogenic, mutagenic and endocrine disruptive properties. If the screening results give rise to concerns, this should give rise to a further effect assessment.
- The effect assessment of the Active Substances, Preparations and Relevant Chemicals, taking the indicated information into account, should be based on internationally recognized guidance (OECD guidelines or equivalent).
- The results of the effect assessment are compared to the results of the discharge toxicity testing. Any unpredicted results (e.g., lack of toxicity or unexpected toxicity in the discharge assessment) should give rise to a further elaboration on the effect assessment.
- An analytical method suitable for monitoring Active Substances and Preparations in ballast water discharges should be available.

3.1.5 Evaluation criteria

The Organization should evaluate the application for approval based on the criteria in this section.

3.1.5.1 The information that has been provided should be complete, of sufficient quality and in accordance with this procedure.

3.1.5.2 That this information does not indicate possible unacceptable adverse effects to environment, human health, property or resources.

3.1.5.3 Ship and personnel safety

- In order to protect the ship and personnel safety the technical group should evaluate the physical and chemical hazards (See paragraph 3.1.3) to ensure that potential hazardous properties of the Active Substances, Preparations or Relevant Chemicals formed in the treated ballast water should not create any unreasonable risk to the ship and personnel.

Proposed procedures for the use and technical equipment introduced needs to be taken into account.

- For the protection of personnel involved in the handling and storage of the Active Substances and Preparations, the proposal should include relevant MSDS. The Organization should evaluate (MSDS, mammalian toxicity data and chemical properties hazards (See paragraph 3.1.3) and ensure that potential hazardous properties of the Active Substances, Preparations or Relevant Chemicals should not create any unreasonable risk to the ship or personnel. This evaluation should take into account the different circumstances that a ship or personnel may face in its trade (e.g., ice, tropical, humidity, etc.).
- A Human Exposure Scenario (HES) should be provided by the applicant as part of the Risk Assessment procedure for ballast water management systems.

3.1.5.4 Environmental protection

- In order to approve the application, the Organization should determine that the Active Substances, Preparations or Relevant Chemicals are not Persistent, Bioaccumulative and Toxic (PBT). Preparations that exceed all these criteria (Persistence, Bioaccumulation and Toxicity) in the table below are considered PBT.

Table 2: Criteria for identification of PBT substances

Criterion	PBT criteria
Persistence	Half-life : > 60 days in marine water, or > 40 days in freshwater *, or > 180 days in marine sediment, or > 120 days in freshwater sediment*
Bioaccumulation	BCF > 2,000 or $\text{LogP}_{\text{octano/water}} \geq 3$
Toxicity	Chronic NOEC < 0.01 mg/l

**For the purpose of marine environmental risk assessment half-life data in freshwater and freshwater sediment can be overruled by data obtained under marine conditions.*

- The Organization should determine the overall acceptability of the risk the Preparation may pose in its use for Ballast Water Management. The risk evaluation should qualitatively take into account cumulative effects that may occur due to the nature of shipping and port operations.
- An Emission Scenario Document (ESD) should be provided by the applicant as part of the Risk Assessment procedure for ballast water management systems. The ESD should be based on the worst-case discharge scenario and should be regarded as the first stage of a stepped approach to the development of a full ESD, when more data on potential discharges and technologies becomes available.

3.1.5.5 Regulation of the use of active substances and preparations

- Handling of Active Substances and Preparations
 - The proposal for approval of Active Substances and Preparations should include information on their intended use and application. The quantity of Active Substances and Preparations to be added to the ballast water and the maximum allowable concentration of the Active Substances therein should be described in the instructions provided by the manufacturer. The system should ensure that the maximum dosage and maximum allowable discharge concentration are not exceeded at any time.
 - An assessment should be undertaken to ensure the safe on-board handling and storage of chemicals used to treat ballast water, using the existing IMO Conventions, Codes and guidance as a basis.
- Hazard documentation and labeling

- The proposal should include (MSDS) as required. The MSDS should describe appropriate storage and handling together with the effects of degradation and chemical reactivity during storage and should be included in the instructions provided by the manufacturer.
- Documentation of hazards or the MSDS should conform to the UN Globally Harmonized System of Classification and Labeling of Chemicals (GHS) and the relevant IMO regulations (e.g. the IMDG Code) and guidelines (e.g. the GESAMP Hazard Evaluation Procedure). Where these regimes are not applicable, relevant national or regional regimes should be followed.
- Procedures and use
 - Detailed procedures and information for safe application of Active Substances and Preparations on board should be developed and supplied, taking into consideration existing IMO Conventions, Codes and guidance. The procedures should comply with the approval conditions such as maximum allowable concentration and maximum discharge concentration, if any.

3.2 Final approval

The process flow diagram for Final Approval is shown below.

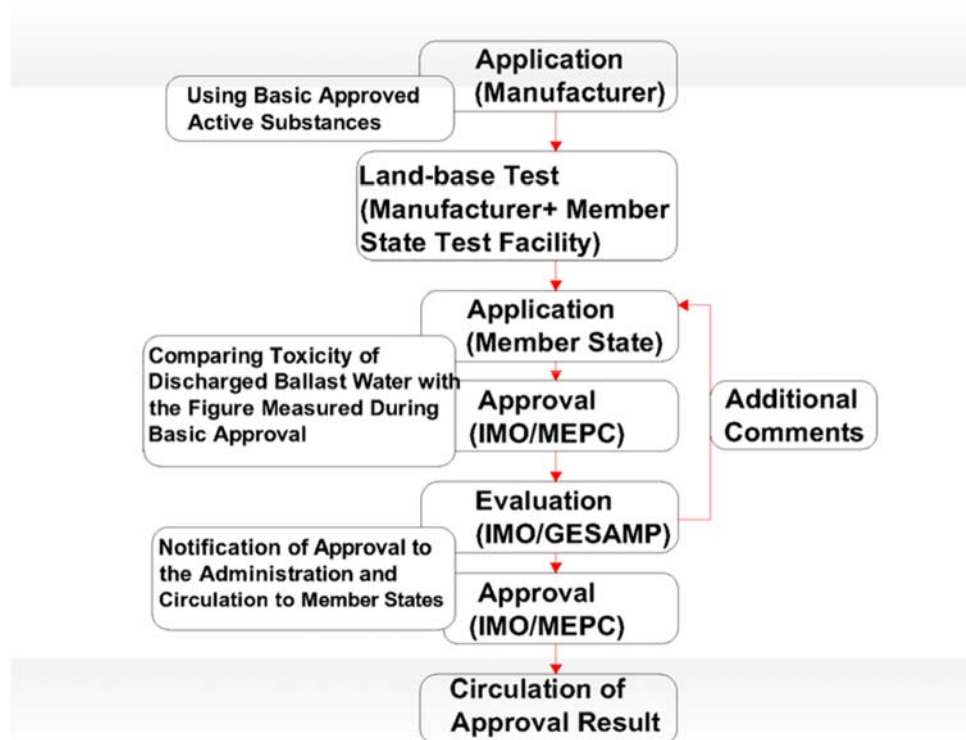

3.2.1 Requirements

3.2.1.1 In accordance with Regulation D-3.2 of the Convention, a Ballast Water Management system using an Active Substance or Preparation to comply with the Convention (Which received basic approval) must be approved by the Organization. For this purpose, the Member of the Organization submitting an application should conduct the Type Approval tests in accordance with Guidelines for Approval of Ballast Water Management Systems (G8). The results should be conveyed to the Organization for confirmation that the residual toxicity of the discharge conforms to the evaluation undertaken for Basic Approval. This would result in Final Approval of the Ballast Water Management system in accordance with Regulation D-3.2. Active Substances or Preparations that have received Basic Approval by the Organization may be used for evaluation of Ballast Water Management systems using Active Substances or Preparations for Final Approval.

3.2.2 Procedure

3.2.2 It is to be noted that from the Guidelines (G8) for land-based testing, only the results of the residual toxicity tests, assessment of PSC corrosion test, etc should be included in the proposal for Final Approval in accordance with Procedure (G9). All other Guidelines (G8) testing remains for the assessment and attention of the Administration / RO.

3.3 Type Approval

3.3.1 Basic approval of the active substances used by the IMO and the final approval of the systems by the IMO are needed prior to the type approval by the Administration / RO. Summary of the total processes involved in BWMS Type Approval is depicted in the below flow chart.

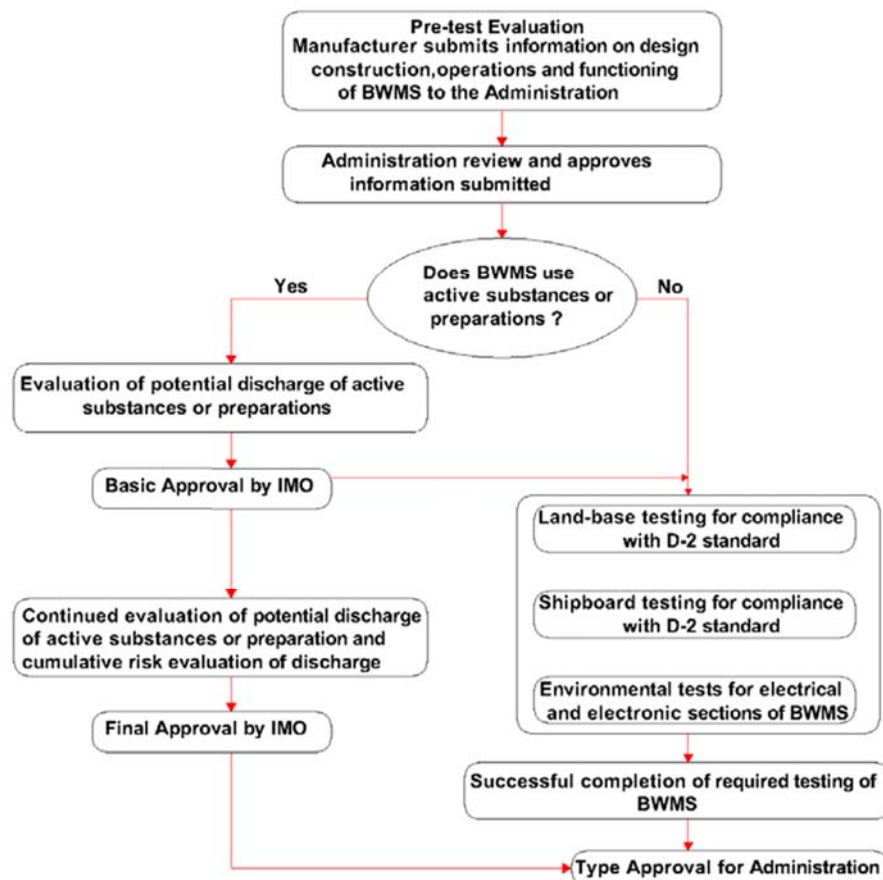

3.4 Notification of approval

3.4.1 Record keeping

3.4.1.1 The Organization will record the Basic and Final Approval of Active Substances and Preparations and Ballast Water Management systems that make use of Active Substances and circulate the list once a year including the following information:

- Name of Ballast Water Management system that make use of Active Substances and Preparations;
- Date of approval;
- Name of manufacturer; and
- Any other specifications, if necessary.

4 MISCELLANEOUS

4.1 Definitions

Administration means the Government of the State under whose authority the ship is operating. With respect to a ship entitled to fly a flag of any State, the Administration is the Government of that State. With respect to floating platforms engaged in exploration and exploitation of the sea-bed and subsoil thereof adjacent to the coast over which the coastal State exercises sovereign rights for the purposes of exploration and exploitation of its natural resources, including Floating Storage Units (FSUs) and Floating Production Storage and Offloading Units (FPSOs), the Administration is the Government of the coastal State concerned.

Organization means the International Maritime Organization

Ship means a vessel of any type whatsoever operating in the aquatic environment and includes submersibles, floating craft, floating platforms, FSUs and FPSOs.

Ballast Water is the water with its suspended matter taken onboard a vessel to control trim, list, draft, stability or stresses of the vessel.

Sediment means matter settled out of Ballast Water within a ship.

Ballast Water Tank is any tank, hold or space used for the carriage of ballast water.

Harmful Aquatic Organisms and Pathogens are aquatic organisms or pathogens which, if introduced into the sea, including estuaries, or into fresh water courses, may create hazards to the environment, human health, property or resources, impair biological diversity or interfere with other legitimate uses of such areas.

Viable Organisms means organisms that have the ability to successfully generate new individuals in order to reproduce the species.

Ballast Water Treatment (BWT) Equipment refers to equipment which mechanically, physically, chemically or biologically processes ballast water, either singularly or in combination, to remove, render harmless or avoid the uptake or discharge of harmful aquatic organisms and pathogens within the ballast water and associated sediments. Ballast water treatment equipment may operate at the uptake or discharge of ballast water, during the voyage, or at a combination of the events.

Type Approval refers to the IMO approval and certification regime of BWMS made by an IMO Member State in accordance with the Convention Guidelines. An approved BWMS is to have a valid Type Approval Certificate in the proper form and signed by that Member State.

Active Substance means a substance or organism, including a virus or fungus that has general or specific action on or against harmful aquatic organisms and pathogens.

Preparation means any commercial formulation containing one or more Active Substances including any additives. This term also includes any Active Substances generated on board for the purposes of ballast water management and any Relevant Chemicals formed in the BWMS that makes use of Active Substances to comply with the Convention.

Relevant Chemicals means transformation or reaction products that are produced during and after employment of the BWMS in the ballast water or the receiving environment and that may be of concern to the ship's safety, aquatic environment and/or human health.

Sampling Facilities refers to the means provided for sampling treated or untreated ballast water.

Treatment Rated Capacity is the maximum continuous capacity expressed in cubic meters per hour for which the BWMS is type approved. It states the amount of ballast water that can be treated per unit time by the BWMS to meet the standard in regulation D-2 of the Convention.

Failed test cycle is a valid test cycle in which the performance of the BWMS resulted in treated water that is determined to be non-compliant with the standard set within regulation D-2. A failed test cycle interrupts the required consecutive test cycles and terminates the test.

Invalid test cycle is a test cycle in which, due to circumstances outside the control of the BWMS, the requirements for a valid test cycle are not met. When a test cycle is invalid, it does not count as one of the required consecutive test cycles in a test and the test can be continued.

Valid test cycle means a test cycle in which all the required test conditions and arrangements, including challenge conditions, test control, and monitoring arrangements (including piping, mechanical and electrical provisions) and test analytical procedures were achieved by the test organization.

Major components means those components that directly affect the ability of the system to meet the ballast water performance standard described in regulation D-2.

System Design Limitations (SDL) of a BWMS means the water quality and operational parameters, determined in addition to the required type approval testing parameters, that are important to its operation, and, for each such parameter, a low and/or a high value for which the BWMS is designed to achieve the performance standard of regulation D-2. The SDL should be specific to the processes being employed by the BWMS and should not be limited to parameters otherwise assessed as part of the type approval process. The SDL should be identified by the manufacturer and validated under the supervision of the Administration, taking into account Guidance developed by the Organization, and in accordance with this Code.

4.2 Appendix-A

BADGE OR CIPHER

(Limiting Operating Conditions apply)*

NAME OF ADMINISTRATION

TYPE APPROVAL CERTIFICATE OF BALLAST WATER MANAGEMENT SYSTEM

This is to certify that the ballast water management system listed below has been examined and tested in accordance with the requirements of the specifications contained in the *Code for Approval of Ballast Water Management Systems* (resolution MEPC.300(72)). This certificate is valid only for the ballast water management system referred to below.

Name of ballast water management system:

Ballast water management system manufactured by:

Under type and model designation(s)

and incorporating:

To equipment/assembly drawing No.: date:

Other equipment manufactured by:

To equipment/assembly drawing No.: date:

Treatment Rated Capacity (m3/h):

A copy of this Type Approval Certificate shall be carried on board a ship fitted with this ballast water management system, for inspection on board the ship. If the Type Approval Certificate is issued based on approval by another Administration, reference to that Type Approval Certificate shall be made.

Limiting Operating Conditions imposed are described in this document.

(Temperature / Salinity)

Other restrictions imposed include the following:

This equipment has been designed for operation in the following conditions:**

Official stamp

Signed

Administration of

Issued this day of 20

Valid until this day of20

* Delete as appropriate.

** Insert System Design Limitations.

4.3 Appendix-B

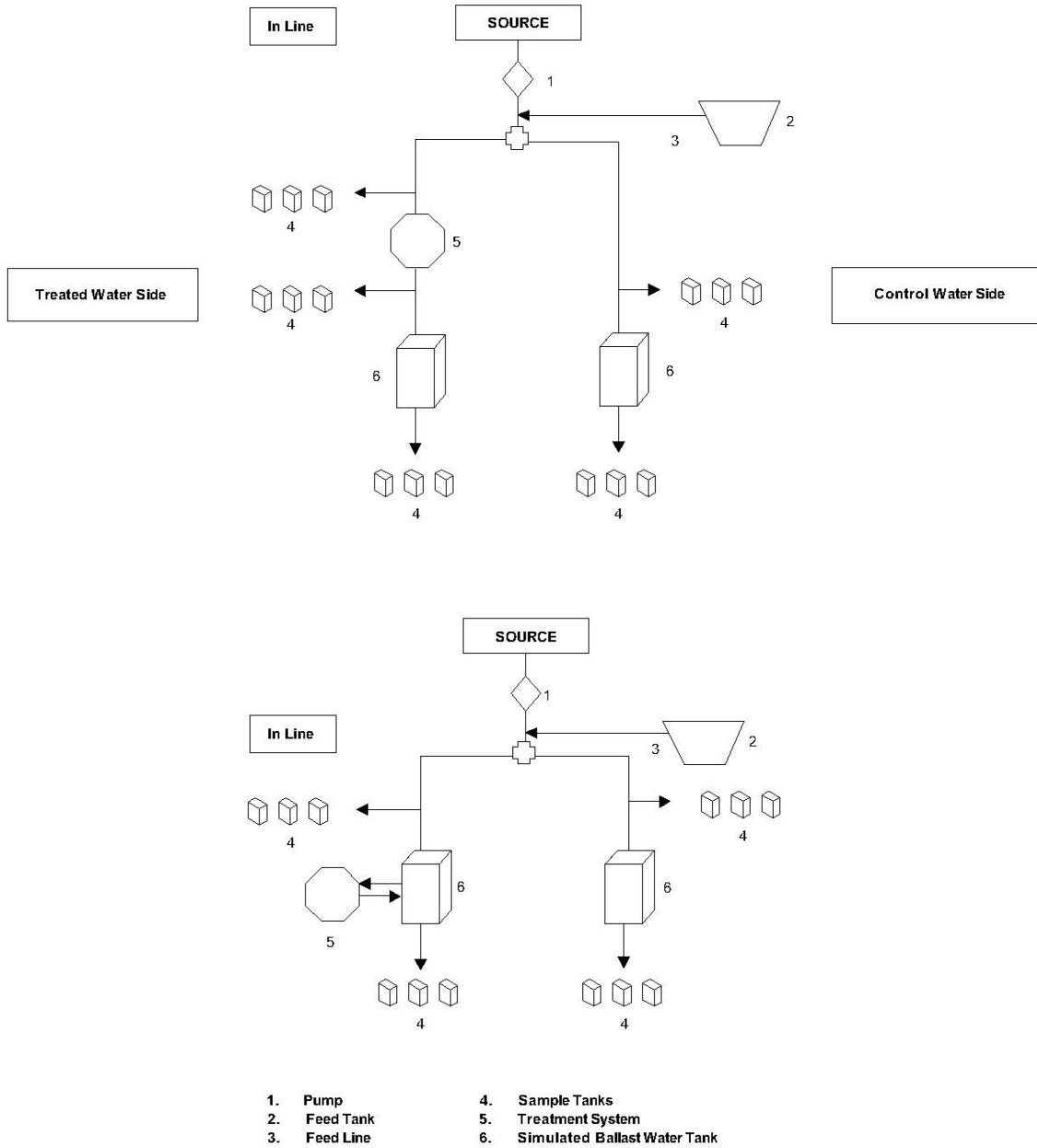

4.4 References

- A. Ballast Water Management Convention 2009 Edition ((IMO Publication)
- B. Suggested sources for non-exhaustive list of standard methods and innovative research techniques for sampling:
 - .1 The Handbook of Standard Methods for the Analysis of Water and Waste Water.
 - .2 ISO standard methods.
 - .3 UNESCO standard methods.
 - .4 World Health Organization.
 - .5 American Society of Testing and Materials (ASTM) standard methods.
 - .6 United States EPA standard methods.
 - .7 Research papers published in peer-reviewed scientific journals.
 - .8 MEPC documents.
- C. Organization for Economic Cooperation and Development (OECD) Guidelines for Testing of Chemicals (1993) or other equivalent tests for the tests for Active Substances and Preparations
- D. For Guidance on preparation of Quality Management Plan (QMP) and a Quality Assurance Project Plans (QAPP) refer International Organization for Standardization (ISO) (www.iso.org)

